

Field Installation Guide

Field Installation Procedures for Design Analysis
WaterLog[®] H3611i Microwave Radar Water Level
Sensor Using the Sutron Data Collection Platform

Version 1.0

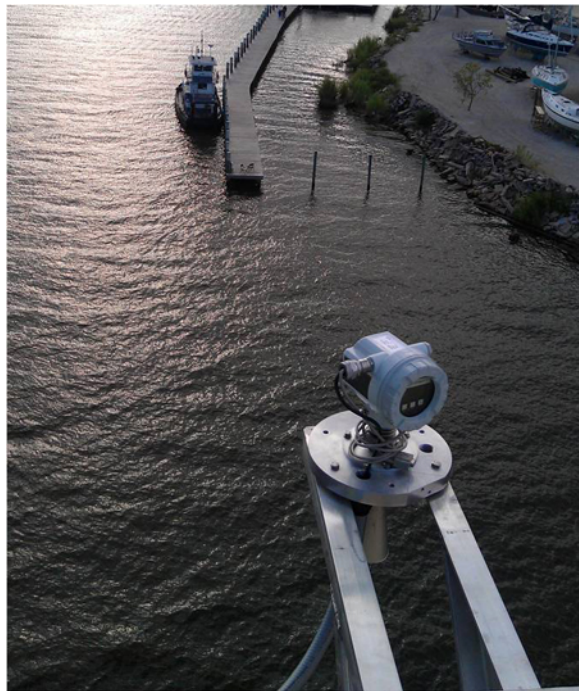

January 2013

noaa National Oceanic and Atmospheric Administration

U.S. DEPARTMENT OF COMMERCE

National Ocean Service

Center for Operational Oceanographic Products and Services

NOTICE

Mention of a commercial company or product does not constitute an endorsement by NOAA. Use of information from this publication for publicity or advertising purposes concerning proprietary products or the tests of such products is not authorized.

Table of Contents

List of Figures	4
List of Tables	4
Foreword	5
Introduction	7
1.0 System Overview.....	9
1.1 Design Analysis WaterLog® Microwave Radar Sensor	9
1.2 Data Collection Platform.....	10
1.3 Data Transmission	12
2.0 Configure WaterLog® Sensor Using the FieldCare (FC) Tool.....	13
3.0 Field Deployment	21
3.1 Make Advance Arrangements with CIL/SIL to Conduct a Real-time Transmission Confirmation after Installation.....	21
3.2 Safety Precautions	21
3.3 Install the WaterLog® Sensor at a Water Level Station	21
Recommended Mounting Guidelines.....	23
Mount the Sensor in the Leveling Collar	23
3.4 Assess Sensor Return Signals after Installation	31
Troubleshooting Envelope Curve Plots	35
Setting the Blocking Distance Parameter on a WaterLog® Sensor	35
3.5 Interface the WaterLog® Sensor and the DCP	37
Wire the Sensor to the DCP	37
Xpert Software Setup.....	38
Set WaterLog® Sensor’s SDI-12 Address to ‘Y’	41
Set WaterLog® Sensor’s Power Mode to ‘Fast Measure’	43
Confirm that Data Are Being Recorded and Transmitted	47
Check 1-Hz Log File	47
Call CIL or SIL to Confirm Transmission of Real-time Data	49
Check <i>Diagtool</i> to Confirm Transmission of Real-time Data (can only be accessed by CO-OPS personnel).....	49
Get PORTS® Tag from the DCP	51
References	53
Appendix A	A-1
Acronyms and Abbreviations	

List of Figures

Figure 1-1.	Design Analysis WaterLog® H3611i	9
Figure 1-2.	Three types of DCPs with interface ports: (a) 9210B XLite, (b) Xpert 2, and (c) Xpert Dark 2.....	11
Figure 2-1.	Wiring diagram for RS232 and SDI-12 interface.....	13
Figure 2-2.	Start the FC software.....	15
Figure 2-3.	Select the connection type.....	16
Figure 2-4.	Shows the main window that appears after a successful connection is made. Sensor parameters that need to be configured are listed under basic setup.	17
Figure 2-5.	Step 1 of saving parameter settings to PDF file.	19
Figure 2-6.	Step 3 of saving parameter settings to a PDF file.	20
Figure 3-1.	Depiction of radar’s dispersive beam with labels representing variables in (1).....	22
Figure 3-2.	Radar sensor bottom of flange to which sensor zero point is referenced.	24
Figure 3-3.	Width of sensor body is larger than diameter of sensor flange, so a level rod could not be set atop the flange.....	24
Figure 3-4.	Engineering drawing of microwave radar sensor leveling collar.	25
Figure 3-5.	Annotated schematic of the WaterLog® sensor’s leveling collar.	26
Figure 3-6.	Actual collar shown in fig. 3-5.....	26
Figure 3-7.	Examples of field installations showing WaterLog® sensor mounted in leveling collar.....	27
Figure 3-8.	Cable run through hole in collar with Liquid-tight conduit attached from below.	28
Figure 3-9.	Examples of geodetic level conducted with leveling point atop the collar surface.	29
Figure 3-10.	Depiction of two different types of installation scenarios; (a) sensor mounted on a structure at the water’s edge and (b) sensor installed on a structure on pilings that extend out into a body of water.....	31
Figure 3-11.	Select Envelope Curve icon	32
Figure 3-12.	Record Envelope Curve icon.....	33
Figure 3-13.	Save Envelope Curve	34
Figure 3-14.	If this prompt appears, click OK.	34
Figure 3-15.	SDI-12 term board for (a) 9210B XLite and (b) Xpert and Xpert Dark.	37
Figure 3-16.	SDI-12 terminal board (paddle board) dropped from DCP’s SDI 12 panel in typical CO-OPS system.	38
Figure 3-17.	Radar display screen.	39
Figure 3-18.	Xpert connect screen.	40
Figure 3-19.	Xpert access selection.	40
Figure 3-20.	Setup Access screen.	41
Figure 3-21.	Select Sensors, then click SDI.....	42
Figure 3-22.	Type AY in the drop-down box.	42
Figure 3-23.	Value ‘Y’ displayed after AY command issued.....	43
Figure 3-24.	Type XRPM and click Send.....	44
Figure 3-25.	Click DO! to display power mode.....	44
Figure 3-26.	Type XWPM1 and then click Send.....	45
Figure 3-27.	Click DO! and then click Close.....	45
Figure 3-28.	Final graphical setup for a WaterLog® sensor, which is configured by CIL/SIL prior to deployment.	46
Figure 3-29.	Start sensor recording.....	47
Figure 3-30.	Select Log tab.....	48
Figure 3-31.	Confirm that data are being recorded.	49
Figure 3-32.	<i>DiagTool</i> main plotting page.....	50
Figure 3-33.	<i>DiagTool</i> plot.....	51

List of Tables

Table 2-1.	Sensor parameters to be set prior to installation.....	18
Table 3-1.	Sensor ranges above water and corresponding footprint widths. Also included are footprint widths divided by 2. The ½ width is the value that determines the length of the extension arm in many installation scenarios.	22
Table 3-2.	Line-by-line interpretation of PORTS® data file.	52

Foreword

In March 2011 the National Oceanic and Atmospheric Administration (NOAA) National Ocean Service (NOS) Center for Operational Oceanographic Products and Services (CO-OPS) Ocean Systems Test and Evaluation Program (OSTEP) published a report that recommended the limited acceptance of the Design Analysis WaterLog[®] H3611i radar for use as a water level sensor at CO-OPS' operational measurement stations. The recommendation was based on results from a series of extensive laboratory and field tests that OSTEP had conducted over three years prior to the release of the report. As a result of this recommendation, CO-OPS has started to transition the microwave radar water level technology to operational applications.

The following document describes the procedure for installing a WaterLog[®] H3611i radar sensor for use as a primary sensor at a CO-OPS water level station. The procedure includes instructions for mounting the sensor, conducting geodetic leveling to the sensor to obtain a datum offset, and integrating the sensor into a CO-OPS water level station that employs one of three different Sutron Data Collection Platform (DCP) models.

Introduction

The procedure required to successfully install and integrate a WaterLog[®] microwave radar range sensor into a CO-OPS water level measurement field site involves the following steps:

1. Prior to entering the field, connect the sensor to a laptop computer equipped with the Windows[®]-based FieldCare (FC) tool software to initiate sensor parameters.
2. Install the sensor at a CO-OPS water level measurement field site using a mounting setup and hardware design that consider both sensor and site location characteristics.
3. After completing sensor installation, interface again using the FC tool and assess sensor return signals to ensure the sensor has a clear, unobstructed view of the water's surface.
4. Interface the sensor to the Data Collection Platform (DCP) and configure the DCP for collection and transmission of WaterLog[®]-measured water level data.

Section 1.0 provides an overview of the system components, section 2.0 describes the procedure for configuring the sensor prior to deployment, and section 3.0 gives detailed instructions for installing a WaterLog[®] sensor at a water level measurement field site and integrating the sensor and Sutron DCP. These instructions assume that the graphical setup for the DCP has already been performed. Although field personnel would need to reconfigure the graphical setup only in rare cases, the instructions for setup reconfiguration are found in appendix A.

1.0 System Overview

This guide provides instructions for installing a water level measurement system, which consists of a Design Analysis WaterLog[®] microwave radar sensor, a Sutron DCP, and data communications hardware for real-time transmission of data via Geostationary Operational Environmental Satellite (GOES).

1.1 Design Analysis WaterLog[®] Microwave Radar Sensor

The Design Analysis WaterLog[®] sensor (fig. 1-1) is a line-of-sight microwave radar instrument that measures range to a target by transmitting a series of pulses, detecting the resulting return echoes, and then using the time of flight of the return pulses to calculate a range to the target. The radar unit is easy to use and works with any data recorder/logger using an SDI-12 interface. For more information, see the vendor-provided sensor manual ([1](#)). A copy of the manual can be found at the Chesapeake Instrument Lab (CIL) and the Seattle Instrument Lab (SIL). Table 1-1 provides the WaterLog[®] sensor specifications.



Figure 1-1. Design Analysis WaterLog[®] H361 li

Table 1-1. WaterLog[®] sensor specifications.

ATTRIBUTE	DESCRIPTION
Maximum Measurement Range	40 m (131 ft)
Data/Power Interface	SDI-12
Frequency of Operation	26 GHz
Voltage Input	10-16 V
Pulse Signal Energy	1 mW max (1μW average)
Beam Angle	10 degrees

1.2 Data Collection Platform

The DCP used with the WaterLog[®] microwave radar sensor in a CO-OPS application can be one of the following Xpert models manufactured by Sutron Corporation: 1) 9210B XLite, 2) Xpert 2, or 3) Xpert Dark 2. Although the location of the sensor's wiring connection to the DCP varies slightly for each DCP type, the operating system and software interface should be the same on all DCPs. The capability to add additional sensors to a total system varies for each DCP type as well, but the initial configuration and interface of a WaterLog[®] to a DCP is the same.

All three Sutron DCP models (fig. 1-2 [a-c]) are based on a 32-bit microprocessor using the Microsoft[®] Windows[®] CE operating system. The 9210B model contains integrated analog and digital I/O modules, four RS232 serial ports, an SDI-12 port and an I²C port for additional I/O modules (fig. 1-3). The Xpert and Xpert Dark models have eight RS232 ports and the I/O modules are connected via the I²C port. All three DCP model systems include a SD data card slot and Ethernet port. Table 1-2 outlines the Sutron DCP system specifications. A full Sutron Xpert manual for each of the three models is available at the CIL/SIL or on the Reliable Operating System (ROS), section 6.3.2.4.

(a) Sutron 9210 XLite DCP



XLite interface ports on DCP bottom



(b) Sutron Xpert DCP



(c) Sutron Xpert Dark
(no GUI screen)



Interface ports at the bottom of the Xpert and Xpert Dark DCPs are identical



Figure 1-2 Three types of DCPs with interface ports: (a) 9210B XLite, (b) Xpert 2, and (c) Xpert Dark 2.

Table 1-2. Sutron DCP Specifications.

32 bit microprocessor running Microsoft® Windows® CE operating system
8 channel digital I/O (6 bi-directional)
10 channel 16 bit A/D inputs (0-5Vdc full scale)
Software control of switched 12 Vdc power on the I/O modules
32MB flash memory
4 RS232 ports that can be used for sensor inputs or outside communications such as LOS radio, GOES satellite, telephone or IP modems.
SD card slot for additional storage
Ethernet port
Input power 10-16 Vdc (40 mA, 230 mA with Display on)

1.3 Data Transmission

The system includes a Sutron Satlink transmitter that provides GPS timing and transmission of the data via GOES every 6 minutes. The system also includes GOES and GPS antennas, which must be mounted with a clear view to the south. The transmitter is programmed through the Sutron DCP.

Data are transmitted one of two ways: either via the PORTS® data acquisition system or GOES. Each way follows the same path as other CO-OPS data types.

2.0 Configure WaterLog[®] Sensor Using the FieldCare (FC) Tool

Prior to field installation of the WaterLog[®] sensor, install the FieldCare (FC) tool on a laptop computer. FC is a vendor-provided, Windows[®]-based software tool made by Endress + Hauser. Use the FC tool to interface with the sensor unit to configure the sensor parameters.

The WaterLog[®] H3611i sensor has a connector cable that provides two types of input/output interface, SDI-12, and RS232. Figure 2-1 shows the pinned end of the cable that connects to the sensor and provides a wiring diagram that displays how to connect to an RS232 block and SDI-12 bus.

The RS232 connection is used to interface the sensor with the FC tool software in order to set the sensor's configuration parameters and assess performance after installation. These actions are required only at specific times, for example, during the initial sensor setup, after initial field installation, or during routine maintenance visits to a field station.

The SDI-12 connection is used for providing power to the sensor and interfacing it to a DCP for continuous real-time data collection. As noted below, the user **must not** interface to the sensor via RS232 and the SDI-12 (white data cable) simultaneously!

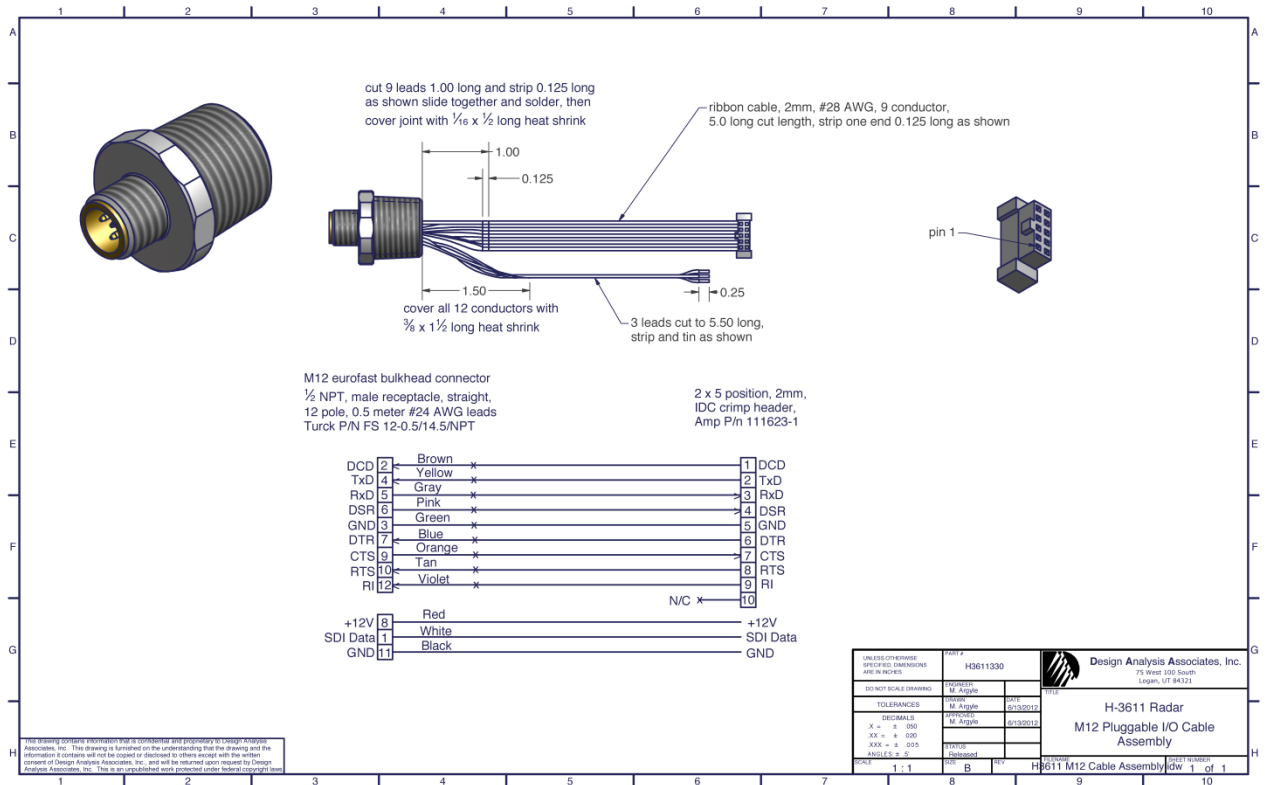

Figure 2-1. Wiring diagram for RS232 and SDI-12 interface.

To configure the WaterLog[®] sensor:

1. Power up the sensor.

The sensor's SDI-12 cable consists of four colored wires with the following functions:

Red: +12 Vdc power

White: SDI-12 data in/out

Black: Ground

Green: Ground

For initial communications, power up the sensor using the red (power in) and black and green (ground) wires and a 12-volt direct current (Vdc) power source with 1 ampere (A) of current.

NOTE:

Shortly after power up, the sensor should start to display real-time range values on its display screen. If nothing appears on the sensor display screen, the sensor most likely is not powered properly. Double check connections and try again.

2. Then, connect the sensor to the computer using an RS232 cable, which is wired according to the diagram in fig. 2-1.

NOTE:

It is possible to power the sensor using the DCP/SDI-12 interface as described in section 3.5; however, when the SDI-12 white data in/out wire is connected to the DCP, communication with the sensor via computer and RS232 is not likely to be successful.

NOTE:

If the sensor is already interfaced to a DCP, **do not** attempt computer-to-sensor communications via RS232. Stop data recording in the DCP and disconnect the SDI-12 white wire prior to starting the FC tool.

3. Confirm that the sensor is powered on and connected to the computer via RS232. Then, run the FC tool software by selecting the desktop icon shown in figure 2-2 (a) (icon should be created on the computer desktop automatically after the software has been installed).

4. The FC startup graphic will appear, along with a notification that the software is searching for installed DTMs [fig. 2-2 (b)]. Allow this process to complete; do not click **Cancel**!
5. The first screen that appears when the FC tool starts (fig. 2-3) will ask the user to select a connection type. Select **HART Point-to-Point**.
6. If a successful connection is made, the screen in fig. 2-4 will appear. From the **Device Setup** window shown in fig. 2-4, all of the WaterLog[®] sensor's parameters can be configured, and sensor return signals (referred to in the FC tool as 'envelope curves') can be recorded and observed.

NOTE: If the initial connection attempt fails, make sure that the **COM** port setting on the FC tool corresponds to the particular **COM** port on the computer to which the sensor will be connected. To set the **COM** port, go to the main menu bar (near top of screen) of the FC tool and select **File**, then **Settings**.

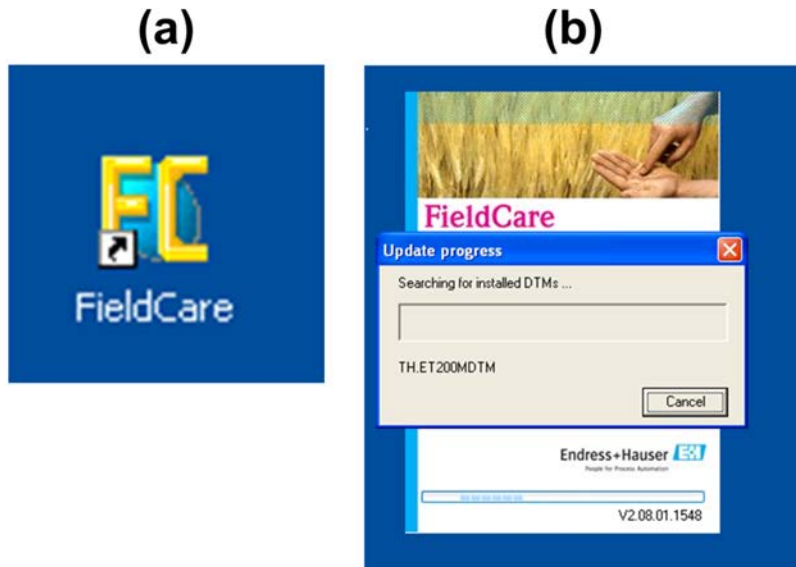

Figure 2-2. Start the FC software.

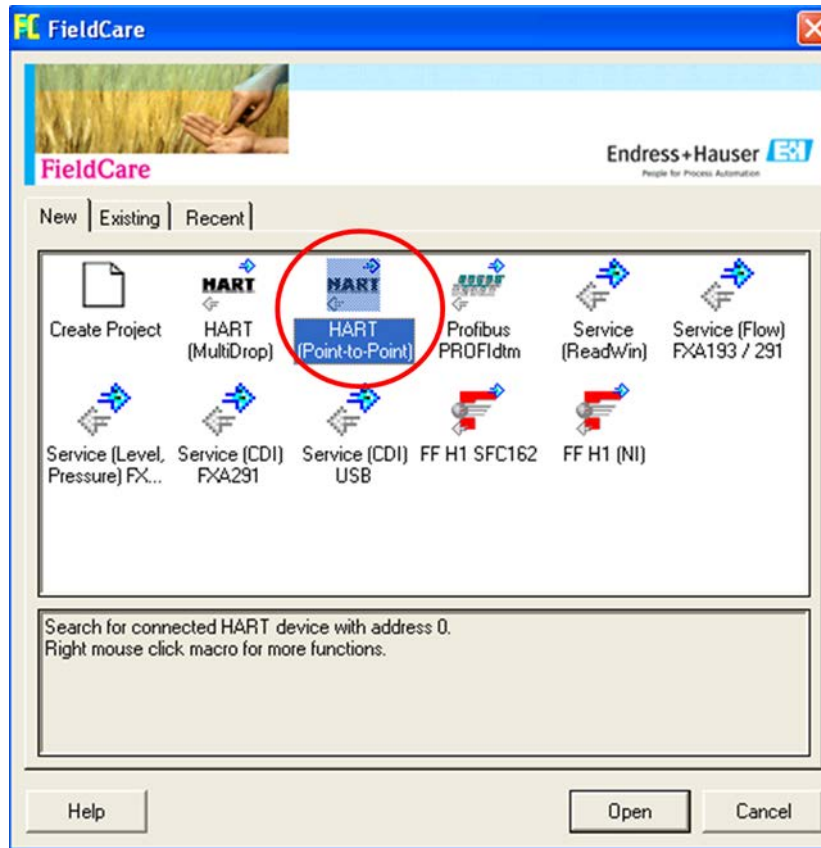

Figure 2-3. Select the connection type.

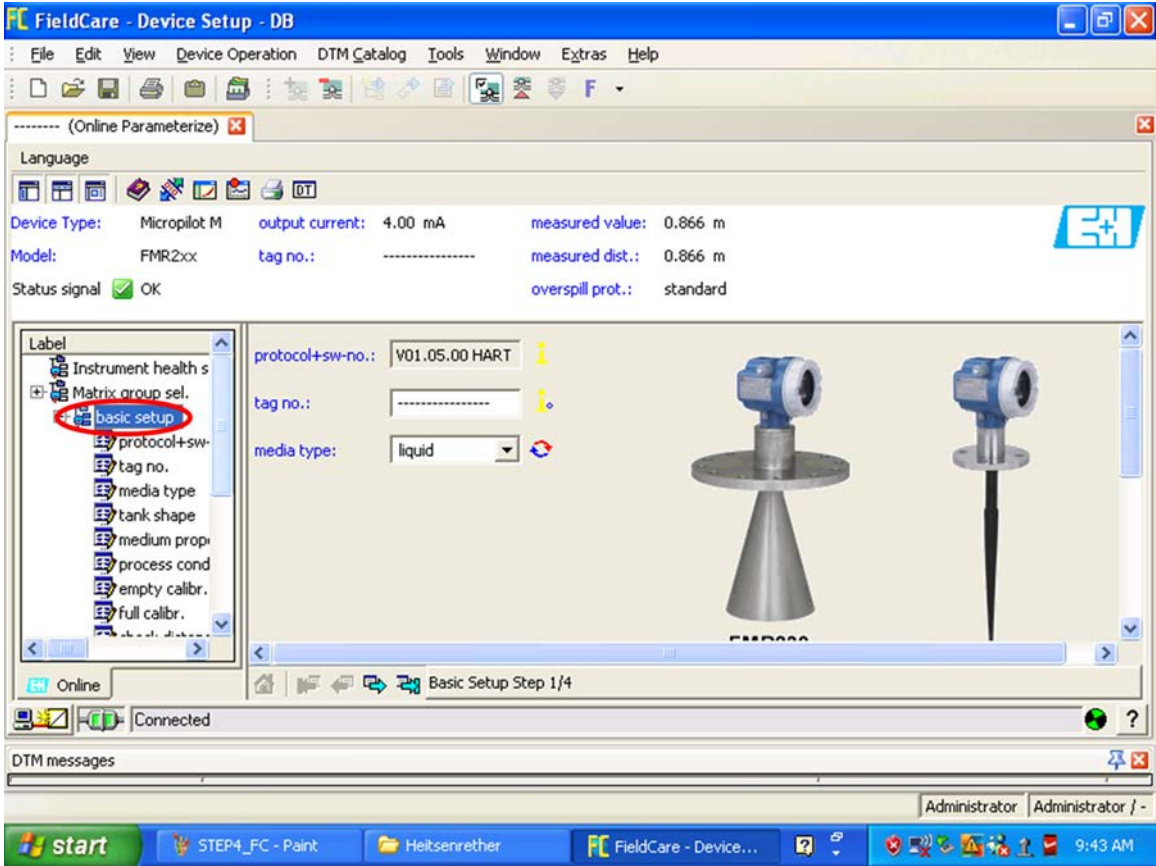

Figure 2-4. Shows the main window that appears after a successful connection is made. Sensor parameters that need to be configured are listed under **basic setup**.

Sensor parameters are organized by groups listed in the **Label** box on the lower left of the **Device Setup** page (e.g., basic setup, safety settings). A parameter group such as **basic setup** can be selected to show the list of individual parameters. To set/change the value of an individual parameter, select it in the list displayed in the **Label** box. Then, a graphic and menu and/or text entry box will appear in the larger box to the right. The example screen capture in fig. 2-4 shows that the group of **basic setup** parameters listed in the **Label** box is selected. The graphic entry box displayed to the right is what will appear when the **media type** parameter is selected.

7. Select individual parameters listed under Parameter Name in table 2-1 using the **Label** box on the lower left side of the **Device Setup** page and set to the values specified in the table. The group name of each parameter is also specified in table 2-1.

NOTE: When entering a new value for any parameter using a text entry box or drop-down menu in the FC tool, be certain to select **Enter to confirm** and wait while the hour glass is displayed to ensure that the change is transferred to the actual sensor.

NOTE:

The parameters **empty calibration** and **full calibration** need to be set to the same value because they both represent the maximum expected sensor-to-water range to be measured. An optimum value for this parameter can be obtained during a field site reconnaissance trip and may be known prior to installation. However, in many cases, an optimum value cannot be determined until the sensor is installed at a site. If you cannot determine the optimum value, you may enter an approximate range value for these two parameters during this first FC tool interface with the sensor. Then, refine the value during the FC tool interface that is required after sensor installation (section 3.4).

NOTE:

Sensor parameters that appear through the FC tool interface but are not listed in table 2-1 are either unused by CO-OPS water level measurement applications and/or can be left at default settings.

Table 2-1. Sensor parameters are set prior to installation.

Group Name	Parameter Name	Value	Comments
basic setup	media type	liquid	
basic setup	tank shape	dome ceiling	Irrelevant to field applications but recommend consistent setting across all CO-OPS sensors
basic setup	medium property	DC: > 10	dielectric constant
basic setup	process condition	fast change	
basic setup	empty calibration	max sensor-to-water range expected at site	
basic setup	full calibration	max sensor-to-water range expected at site	empty calibration' and 'full calibration' need to be set to the same value
extendedcalbr.	offset	0 m	
extendedcalbr.	output damping	0 s	
extendedcalbr.	blocking dist.	0.216 m	length of sensor's metal horn
extendedcalbr.	antenna extens.	0 m	

Once you have finished setting all parameters listed in table 2-1, it is very important to use the FC tool to print and save a parameter list in a PDF file, and then send this file to CIL or SIL for proper archiving.

To save parameter settings using FC:

1. Select the printer icon on the **Device Setup** window marked in fig. 2-5.

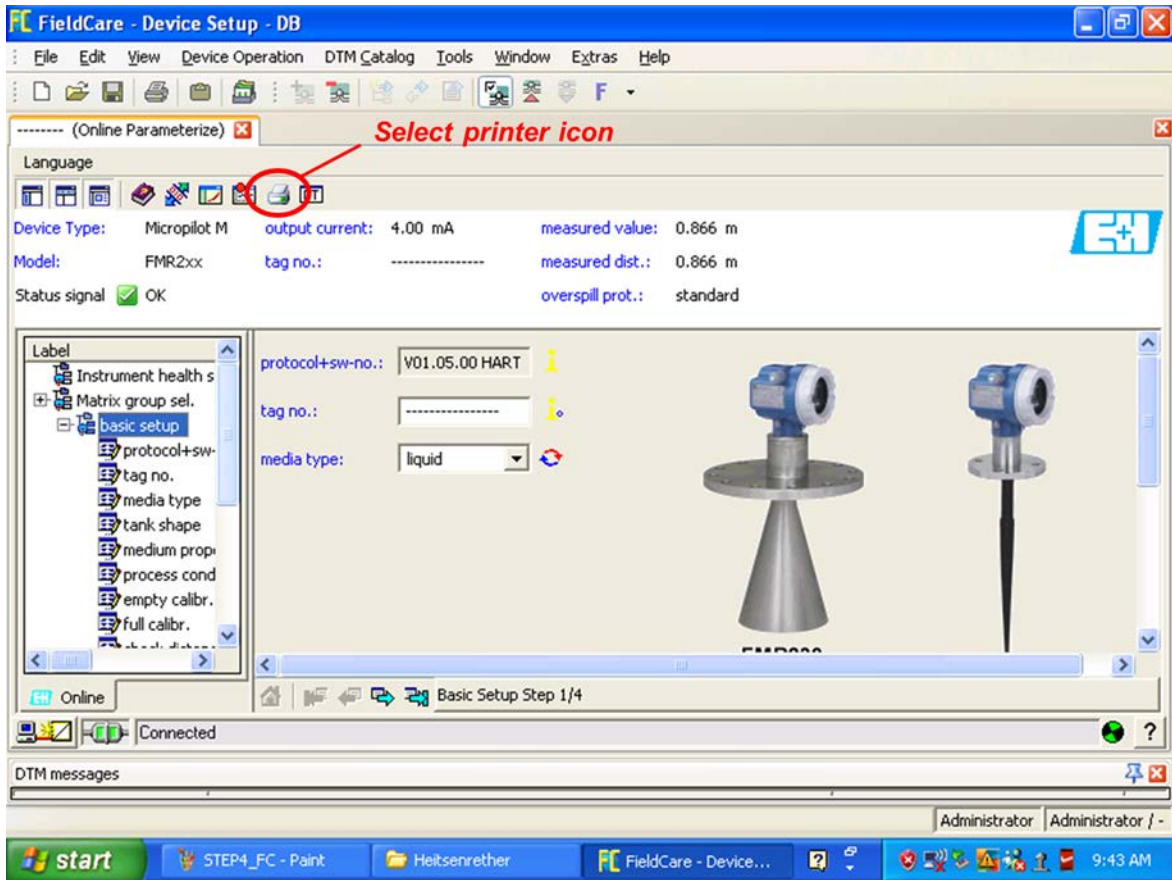

Figure 2-5. Step 1 of saving parameter settings to PDF file.

2. When the **Create Documentation** window appears follow the steps in fig. 2-6.
3. Use the following format for naming the parameter listing file:
SRNM_YYYY_MMDD_LOC where:
SRNM = the sensor's 4-digit serial number
YYYY_MMDD = the year, month, and day the file was created
LOC = where the file was saved, LAB or FIELD
4. When you have finished using the FC tool to set and save parameters, go to the **File** menu and click **Exit**. You will be asked if you would like to **Save Project?** Click **No** to exit the program or **Cancel** to resume use of the FC tool.

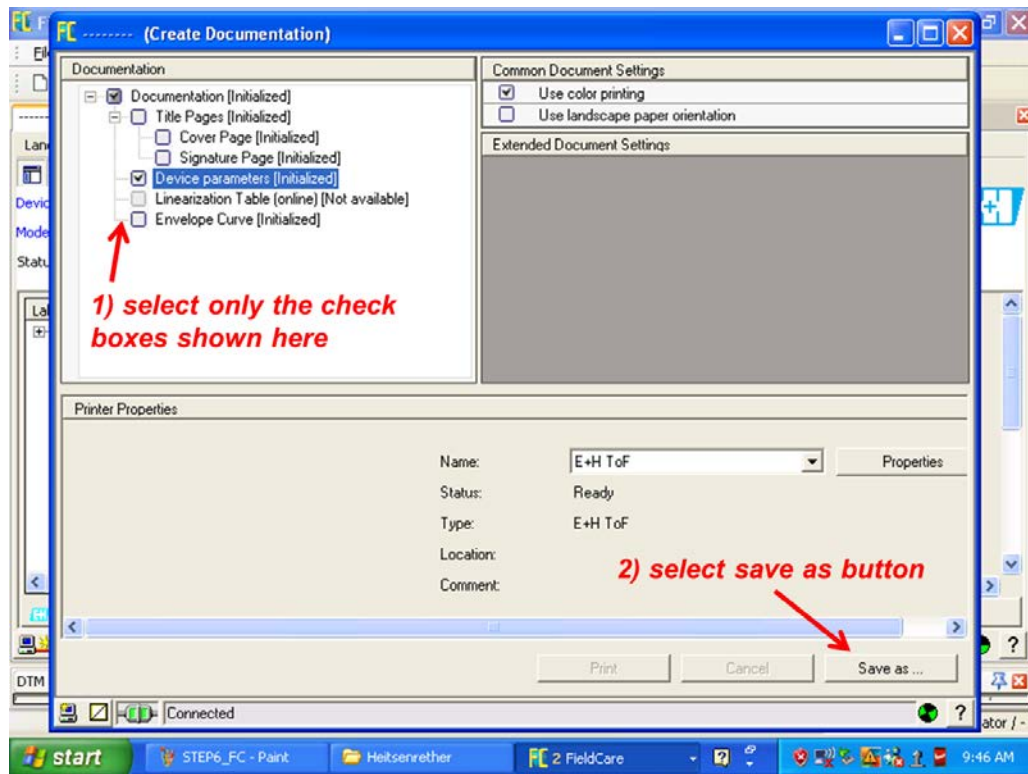

Figure 2-6. Step 3 of saving parameter settings to a PDF file.

3.0 Field Deployment

The following sections cover the procedures required to install a WaterLog[®] radar sensor at a field location, integrate the sensor and the Sutron DCP, and ensure that water level is being properly measured once the sensor is functioning properly.

3.1 Make Advance Arrangements with CIL/SIL to Conduct a Real-time Transmission Confirmation after Installation

After the installation of the WaterLog[®]/DCP system is complete (see section 3.5), conduct a series of checks to confirm that the sensor is recording data, and data are being transmitted as expected. One critical system check involves calling a CIL/SIL point of contact (POC) to confirm that real-time 6-minute data are being transmitted via GOES. To ensure that this real-time transmission check goes smoothly while on site, make arrangements with a CIL/SIL POC prior to the field installation to ensure that s/he will be available to receive a phone call and assist with this request. At least a week prior to the planned installation at a field site, contact the CIL/SIL lead and provide possible dates and an approximate timeframe of the planned installation. Identify a POC to call from the field after the installation. Further details about guidelines for calling a CIL/SIL POC for an after-installation real time transmission check can be found in section 3.5.

3.2 Safety Precautions

During installation of equipment for any CO-OPS field application, personnel must comply with all *NOAA Safety Rules* (draft 4/1/03) and *CO-OPS Field Facility Safety Rules* (draft 4/7/04). NOAA and CO-OPS safety rules vary, depending on the details of specific field locations, so be sure to review the rules and have all the required safety equipment prior to deployment. Hard copies of this safety information can be found in the CO-OPS Chesapeake facility library or on the ROS. Bridge safety and traffic-control coordination with local agencies are critical elements in planning and installation.

3.3 Install the WaterLog[®] Sensor at a Water Level Station

When installing a WaterLog[®] radar sensor to measure water level, you must consider both the characteristics of the sensor and the site location to ensure that the sensor is mounted to obtain the best possible field of view of the water surface and to decrease the likelihood of receiving ‘false echoes’ from nearby obstructions.

Since a WaterLog[®] sensor’s beam is dispersive and spreads at a 10° angle, the sensor’s footprint increases linearly with range, as depicted in fig. 3-1. Sensor footprint width as a function of sensor height above water can be calculated as a function of range using simple trigonometry:

$$X = 2R \tan \frac{\alpha}{2} \tag{1}$$

where α is beam spreading angle (10° for WaterLog[®] radar), R is the range from the sensor's zero point to the target (here, the height above the water surface in the application of interest), and X is the sensor footprint width. Table 3-1 includes sensor ranges above water and corresponding footprint widths (in both meters and feet).

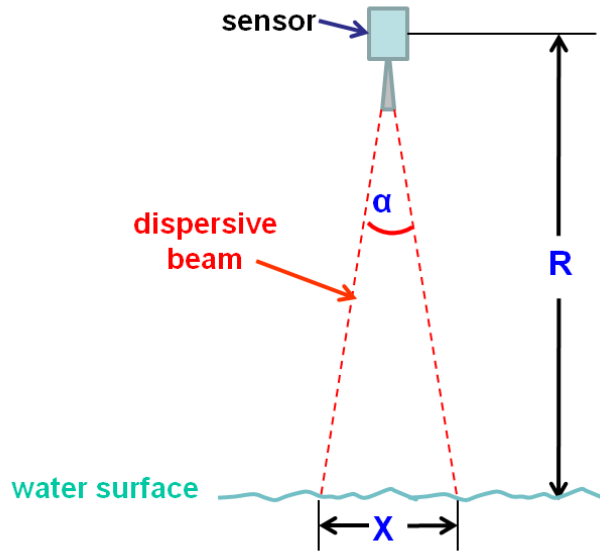

Figure 3-1. Depiction of radar’s dispersive beam with labels representing variables in (1).

Table 3-1. Sensor ranges above water and corresponding footprint widths. Also included are footprint widths divided by 2. The ½ width is the value that determines the length of the extension arm in many installation scenarios.

Sensor to Water Range (meters)	Sensor Footprint Width (meters)	1/2 of Sensor Footprint Width (meters)	Sensor to Water Range (feet)	Sensor Footprint Width (feet)	1/2 of Sensor Footprint Width (feet)
1	0.17	0.09	3.28	0.57	0.29
2	0.35	0.17	6.56	1.15	0.57
3	0.52	0.26	9.84	1.72	0.86
4	0.70	0.35	13.12	2.30	1.15
5	0.87	0.44	16.40	2.87	1.44
6	1.05	0.52	19.69	3.44	1.72
7	1.22	0.61	22.97	4.02	2.01
8	1.40	0.70	26.25	4.59	2.30
9	1.57	0.79	29.53	5.17	2.58
10	1.75	0.87	32.81	5.74	2.87

There are several options for where and how a WaterLog[®] sensor should be installed at a particular station, so a ‘one size fits all’ solution on how to mount the sensor cannot be provided. However, several recommended mounting guidelines based on sensor characteristics are provided in the following paragraphs.

Recommended Mounting Guidelines

To start, follow the list of installation guidelines provided in section 2.3 of the WaterLog[®] H3611i Owner's Manual [1], paying special attention to specific guidelines. In any deployment scenario, you must ensure that the sensor is (1) securely mounted to eliminate any possible type of sensor motion, and (2) oriented to aim directly downward at the water so that the line of transmission is as close as possible to being perpendicular to the mean sea surface.

Mount the Sensor in the Leveling Collar

A special geodetic leveling collar was designed by CO-OPS for mounting the WaterLog[®] sensor. The collar provides a flat surface to which a datum offset can be measured. The top of the collar provides an ample area for setting the base of a geodetic leveling rod, and a leveling tape can be hung from an area alongside the collar. The following paragraphs describe the leveling collar design and include instructions on how to incorporate the collar into a WaterLog[®] sensor's mounting setup.

The WaterLog[®] sensor's zero range point can be easily referenced to the bottom of the circular flange that is used for mounting the sensor (fig. 3-2). However, because the width of the sensor's electronics housing (fig. 3-3 green arrows) is larger than the diameter of the sensor's flange (fig. 3-3 red arrows) in every rotational direction (looking downward onto the sensor's top), it is difficult to properly place a long leveling rod atop the sensor's flange. If the sensor's zero point is referenced to the bottom of the circular flange, (fig. 3-2), the sensor can be mounted so that this flange bottom sits flush against another flat metal surface. The flat surface provides additional area for rod placement, which is at the same vertical location as the sensor's flange bottom.

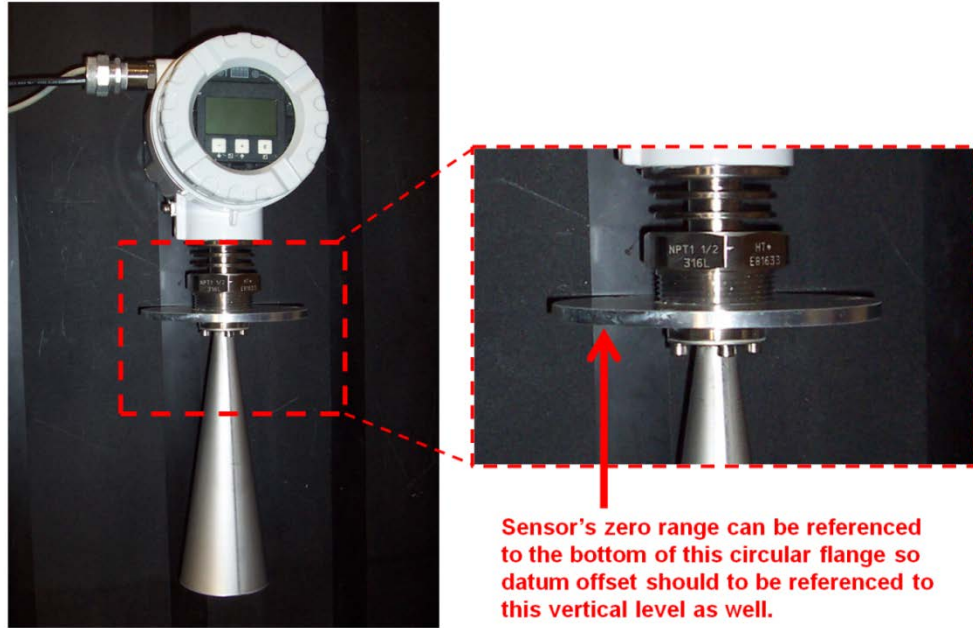

Figure 3-2. Radar sensor bottom of flange to which sensor zero point is referenced..

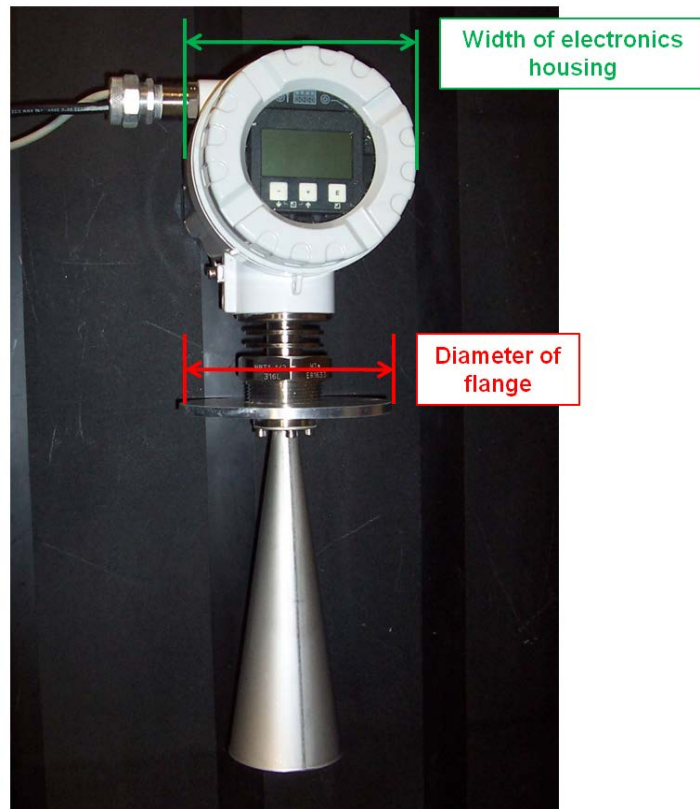

Figure 3-3. Width of sensor body is larger than diameter of sensor flange, so a level rod could not be set atop the flange.

The leveling collar’s design is shown in an engineering drawing in fig. 3-4, in an annotated diagram in fig. 3-5, and in a picture in fig. 3-6. The collar is a 1-inch thick circular disc made from aluminum (the same material as the sensor’s circular flange). It has large hole in the center through which the sensor’s horn can be fitted (fig. 3-5 [d]), allowing the bottom of the sensor’s flange to sit flush atop the collar surface. The outer edge of the collar contains holes for hardware that will attach the collar to the sensor mounting arm or extension (fig. 3-5 [a]), and the collar’s inner region contains holes for hardware to attach the sensor to the collar (fig. 3-5 [b]).

During geodetic leveling, a vertical datum offset is measured to the top of the collar surface. The collar surface has a marked leveling point that specifies where a rod or tape should be placed (fig. 3-5 [f]).

In most installation setups, only three bolts are required to attach the collar to a particular mounting hardware setup. However, six holes are included in the collar (fig. 3-5[a]) to allow for rotation and flexibility in orientation, depending on where the installer prefers to orient the leveling point. The same is true for the sensor mounting holes (fig. 3-5 [b]). Only three bolts are needed to attach the WaterLog[®] sensor to the collar; however, six holes are available to allow flexibility in rotational positioning of the sensor. Examples of the installation of mounting hardware, collar and sensor are shown in fig. 3-7.

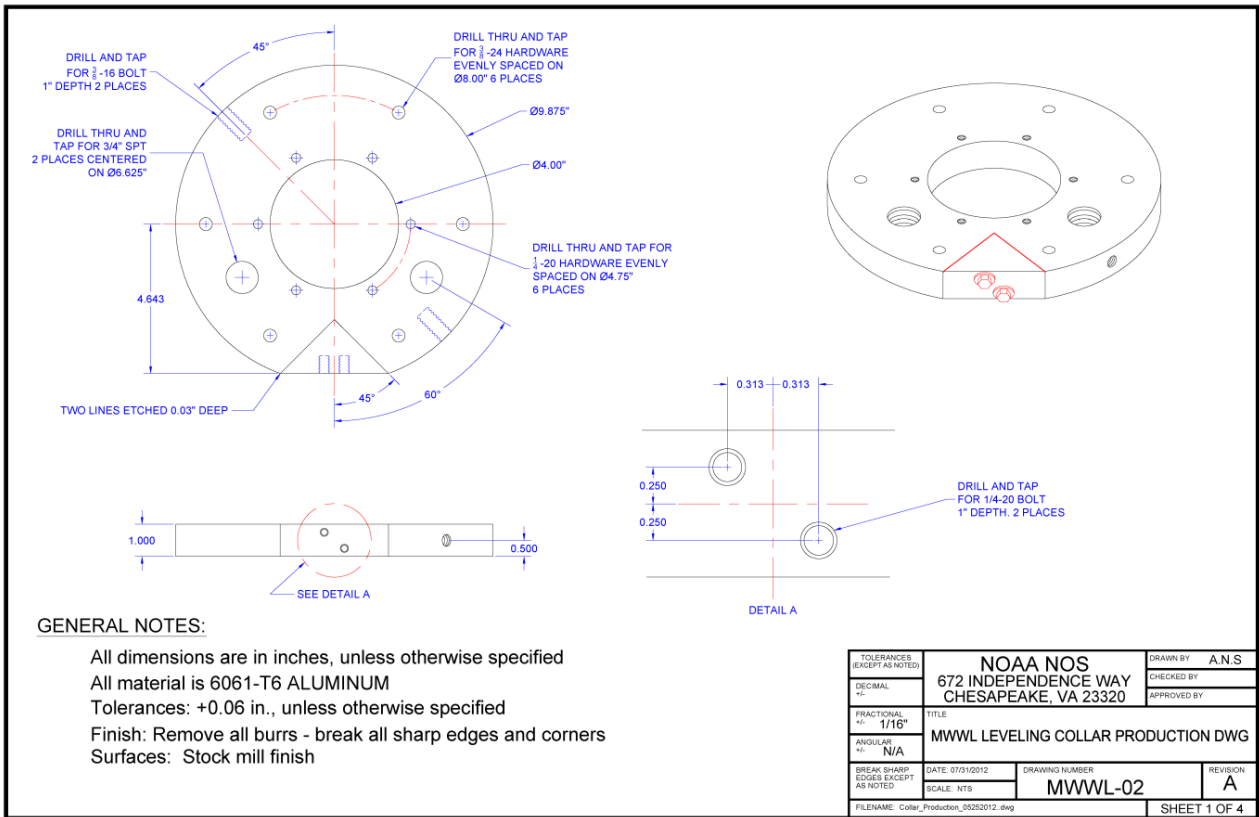

Figure 3-4. Engineering drawing of microwave radar sensor leveling collar.

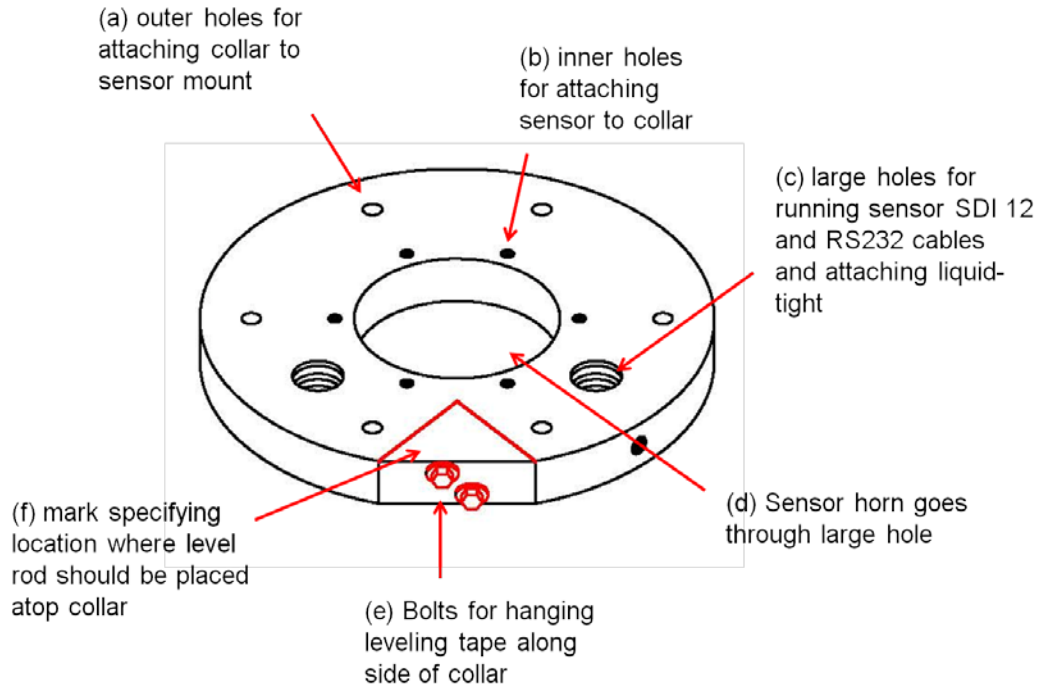

Figure 3-5. Annotated schematic of the WaterLog[®] sensor's leveling collar.



Figure 3-6. Actual collar shown in fig. 3-5.

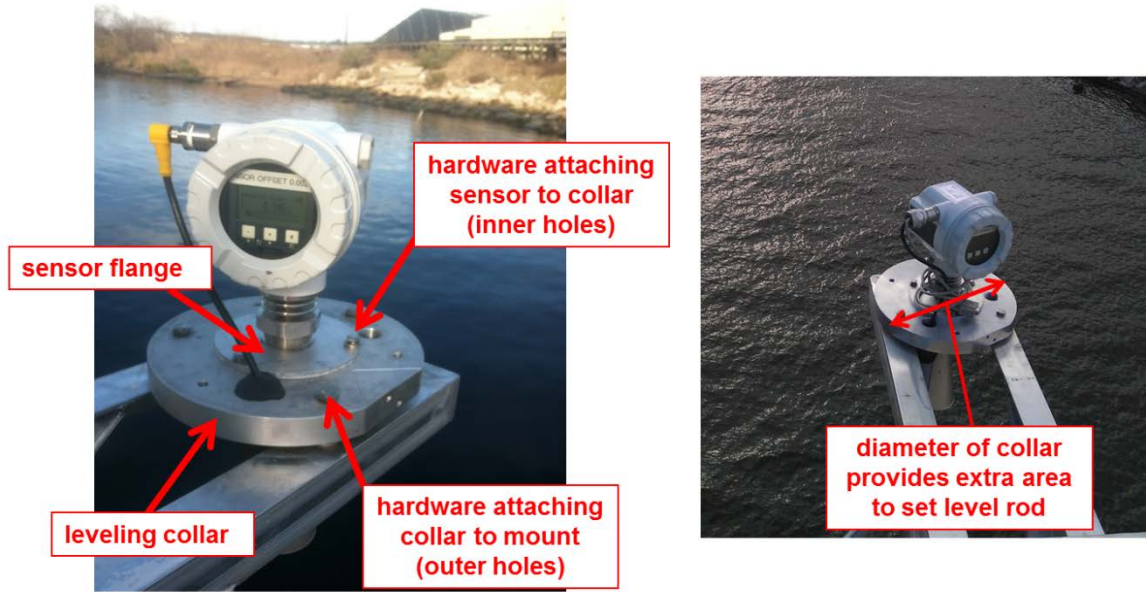

Figure 3-7. Examples of field installations showing WaterLog[®] sensor mounted in leveling collar.

Follow these steps to install the leveling collar and WaterLog[®] sensor:

1. Attach the leveling collar to whatever arm, bracket, or other mounting hardware is being used to extend the WaterLog[®] radar over the water column to have a clear view of the sea surface (examples shown in fig. 3-7). Use three bolts through the outer holes on the collar. The collar has six holes and the flange has three, which means that collar holes and flange holes have to line up.
2. Ensure that the collar is level to within approximately ≤ 1 degree. Ideally, the mounting hardware that the collar is attached to should be level, but if not, add washers underneath the collar around any of the three mounting bolts as necessary to get the collar surface level.
3. Attach the WaterLog[®] sensor to the collar as shown in fig. 3-7; put the antenna horn through the large center hole in the collar, ensure the sensor flange rests flush atop the collar, and attach with the mounting hardware through the three holes in the sensor flange.
4. Run the sensor cabling through the appropriate hole on the leveling collar (fig. 3-5 [c]).
5. Run the cable through a Liquid-tight conduit to the DCP enclosure box and screw the threaded end of the conduit to the collar hole through which cable is run (fig.3-8).
6. After sensor is installed in the collar on the mount, conduct geodetic leveling to measure a vertical datum offset to the mark specifying the leveling point atop the collar surface (fig. 3-5 [f]) (fig. 3-9).



Figure 3-8. Cable run through hole in collar with Liquid-tight conduit attached from below.

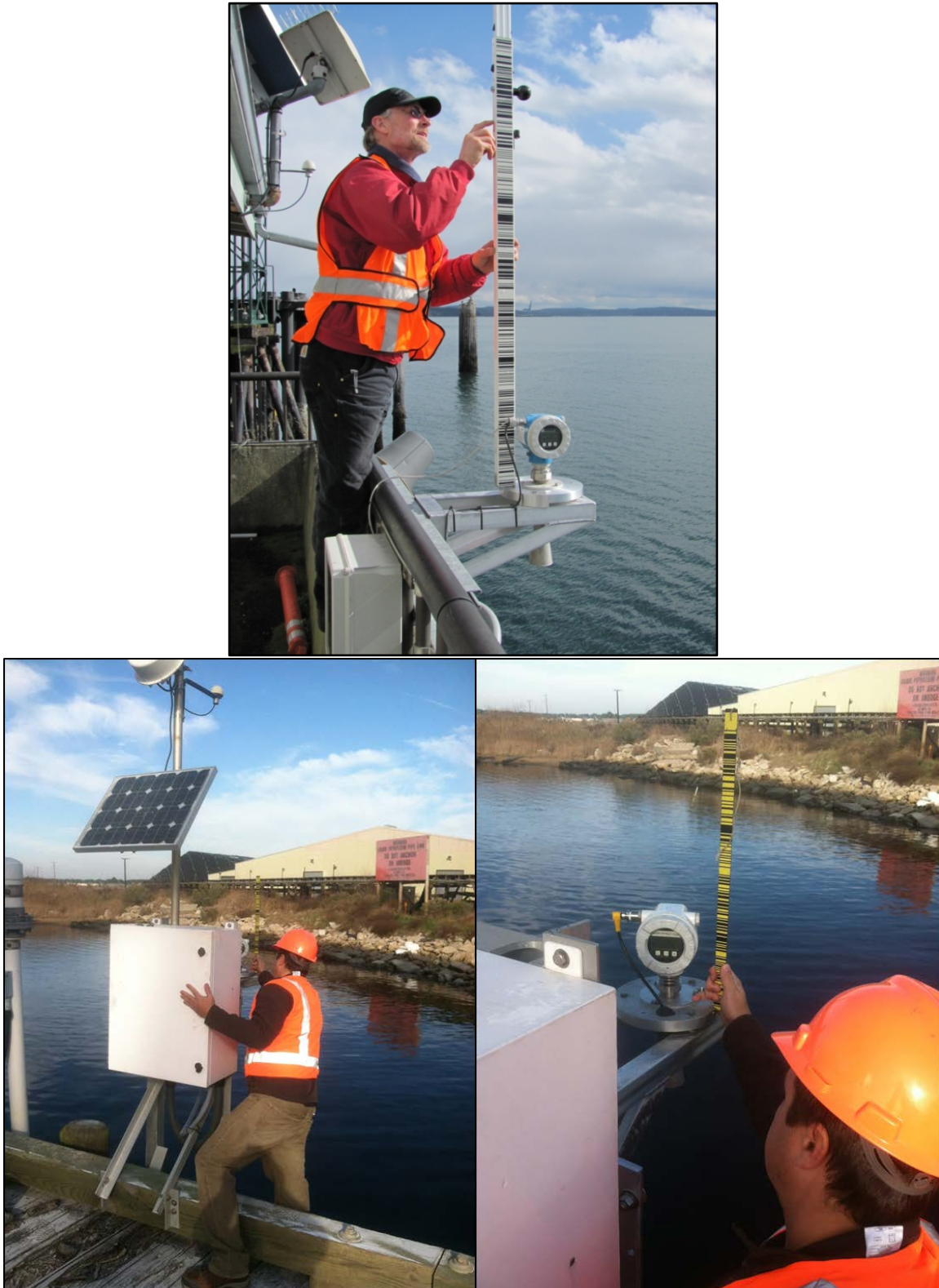

Figure 3-9. Examples of geodetic level conducted with leveling point atop the collar surface.

Essential Information for Sensor Mounting

After a sensor is installed in a mount, it must not rock, vibrate, or undergo any high frequency motion within that mount under any circumstances, including during a high wind storm event. Any high frequency motion that a microwave radar sensor undergoes will result in noise contamination of the 1-Hz water level series, which may be in the same frequency band as that induced by sea surface roughness. In addition, the mount and installation configuration must ensure that the sensor does not undergo any long-term deviation from its vertically referenced position initially obtained during the post-installation geodetic survey (which is the case for any water level sensor that is vertically referenced to some bench mark on land). Any extension arm incorporated into a station design must be completely rigid and securely fastened to an equally rigid and static base structure.

When orienting a sensor's transition path to aim directly at the water surface, you must vertically align the sensor's horn antenna within $\leq 1^\circ$. If the antenna is not vertical, the sensor's range measurement is affected by trigonometric error with respect to the water. Therefore, return signal levels may be too weak for detection when they reach the maximum specified range.

To obtain accurate data with the WaterLog[®] H3611i sensor, you must ensure that the sensor's transmission footprint has a clear, unobstructed view of the water surface. You may be able to install the sensor on a tower or elevated platform that is mounted on a solid structure at the water's edge, for example, a seawall or bulkhead (fig. 3-10 [a]). In this type of setup, the sensor may require a horizontal extension arm to place it far enough out from the tower or mounting structure to ensure that the sensor's beam does not interfere with the objects on or near the water's edge. As depicted in fig. 3-10 (a), one-half of the sensor footprint's width (table 3-1) is used to determine the length of the sensor's mounting arm. Any extension arm that is used must be rigid to prevent sensor motion after mounting.

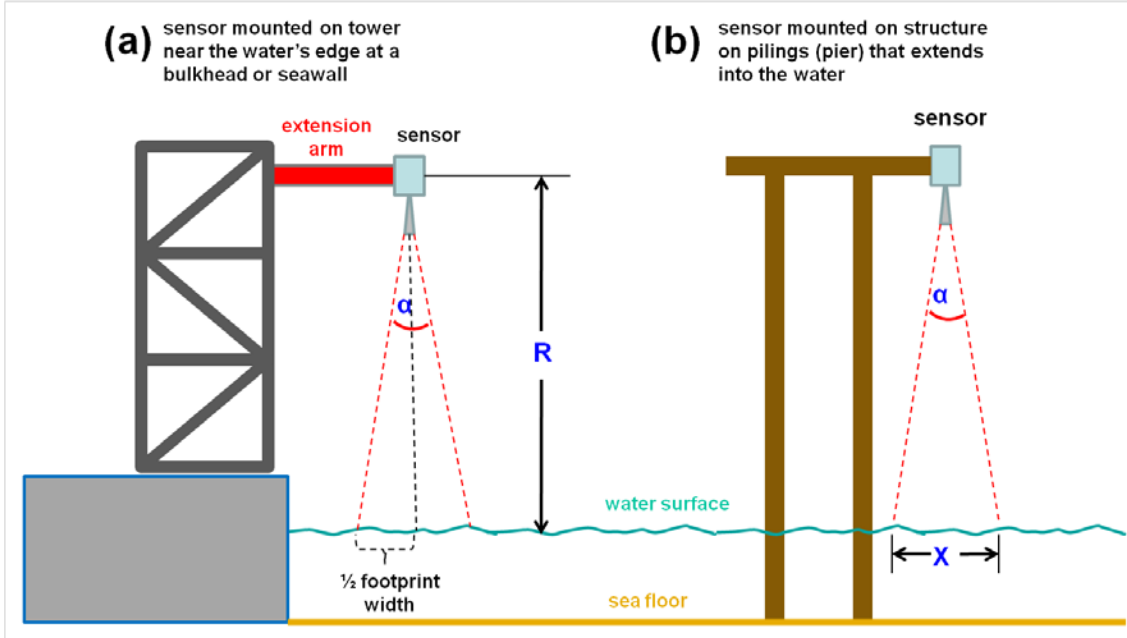

Figure 3-10. Depiction of two different types of installation scenarios; (a) sensor mounted on a structure at the water’s edge and (b) sensor installed on a structure on pilings that extend out into a body of water.

You may also install a WaterLog[®] radar sensor on a structure that is on pilings and extends out into a body of water, such as a pier. Depending on the characteristics of the pier, this installation scenario (fig. 3-10 [b]) may not require an extension arm. If the sensor is mounted such that the beam footprint meets the sea surface in an area between piling structures, the sensor can possibly be mounted at the edge of the platform atop the pilings—on a railing at the edge of a pier, for example.

Rules of WaterLog[®] Sensor Installation/Mounting

- Mounting hardware must not move
- Sensor antenna must be vertically aligned within $\leq 1^\circ$
- Sensor transmission footprint must have unobstructed view of the water surface

3.4 Assess Sensor Return Signals after Installation

Immediately following completion of the physical installation and mounting of a WaterLog[®] microwave radar sensor at a field site, you must measure the sensor’s return signal and assess it to (1) check whether the sensor has a clear, unobstructed view of the water surface and (2) determine if there is a sharp peak in the return signal plot (referred to as **Envelope Curve** in the FC tool) corresponding to the water surface. To measure and assess sensor return signals, communicate with the radar sensor using a laptop computer via RS232 and the FC tool software, following the same procedure described in section 2.0. When communicating with a WaterLog[®] sensor in the field via

RS232 and the FC tool software, make sure that (1) the sensor is not logging measurements to a DCP, and (2) the sensor's SDI-12 data wire (white wire as specified in section 2.0) is not connected to the DCP's SDI-12 port.

1. Ensure that the WaterLog[®] sensor is powered up but not logging data (the sensor's white SDI-12 wire is not connected to anything).
2. Connect the sensor's RS232 cable to the COM port on a laptop computer that contains the FC tool software.
3. Repeat steps shown in figs. 2-1 through 2-5 to start up the software and to establish a connection to the sensor.
4. Once a connection is established, select the **Envelope Curve** icon in FC tool window (fig. 3-11).

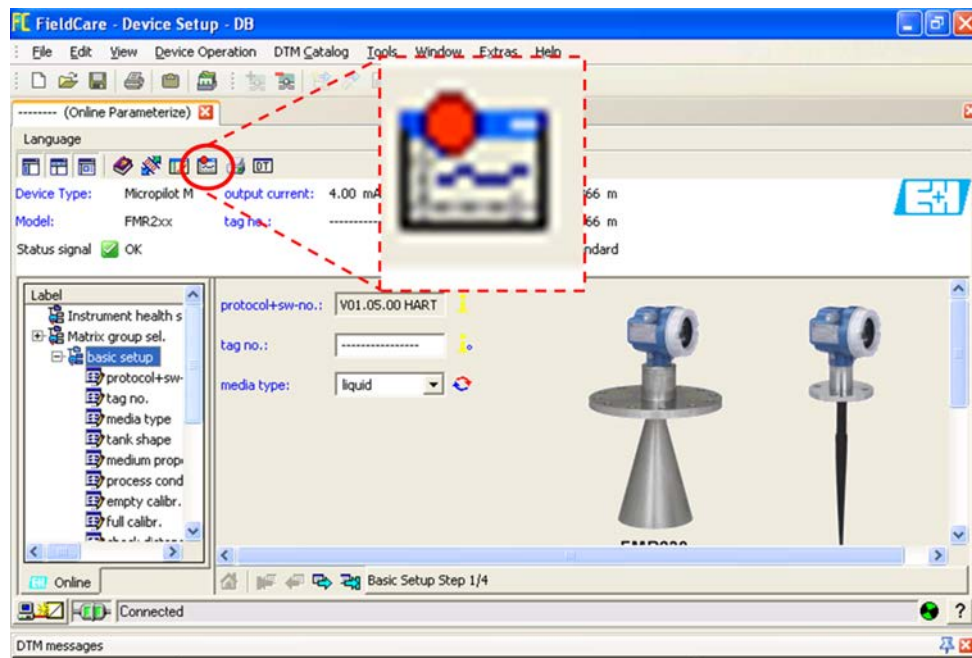

Figure 3-11. Select **Envelope Curve** icon

5. An additional window and associated tab will appear for the **Envelope Curve**. Select the record button, which is a red circle on the third row menu bar at the top of the window (fig. 3-12).

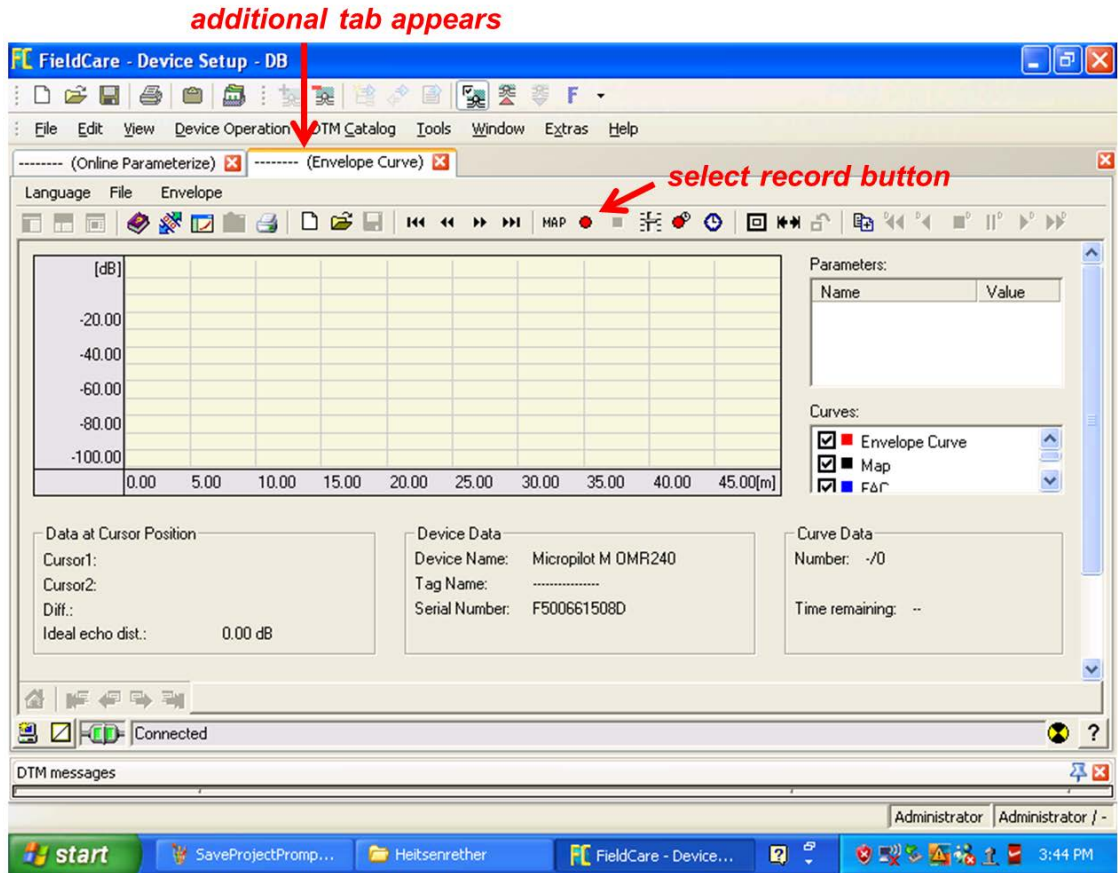

Figure 3- 12. Record **Envelope Curve** icon.

The red line representing the return signal will appear in the plotting area, resulting in a range (X-axis) versus intensity (Y-axis) plot. A black X on the plot marks the peak that was selected to represent the return from the target that is being measured. Next to the X, an exact range value (meters or m) and peak signal level (dB) are displayed.

The signal plot in fig. 3-13 is from a sensor 2.66 m away from a fixed target, with no obstructions. Note that the **max range** setting is at 45 m for this sensor, so a few secondary peaks corresponding to multipath signal reflections can be seen (signals are reflected from the target, then off of the sensor platform and back to the target, etc.).

6. After a return signal plot appears, save the file to a .Crv file by selecting the disk icon in the **Envelope Curve** window (fig. 3-13). If the prompt shown on fig. 3-14 appears, click **OK**.

Use the following format for naming the envelope curve file:

SRNM_YYYY_MMDD_EnvCrv where:

SRNM = the sensor's 4-digit serial number

YYYY_MMDD = the year, month, and day when the file was created.

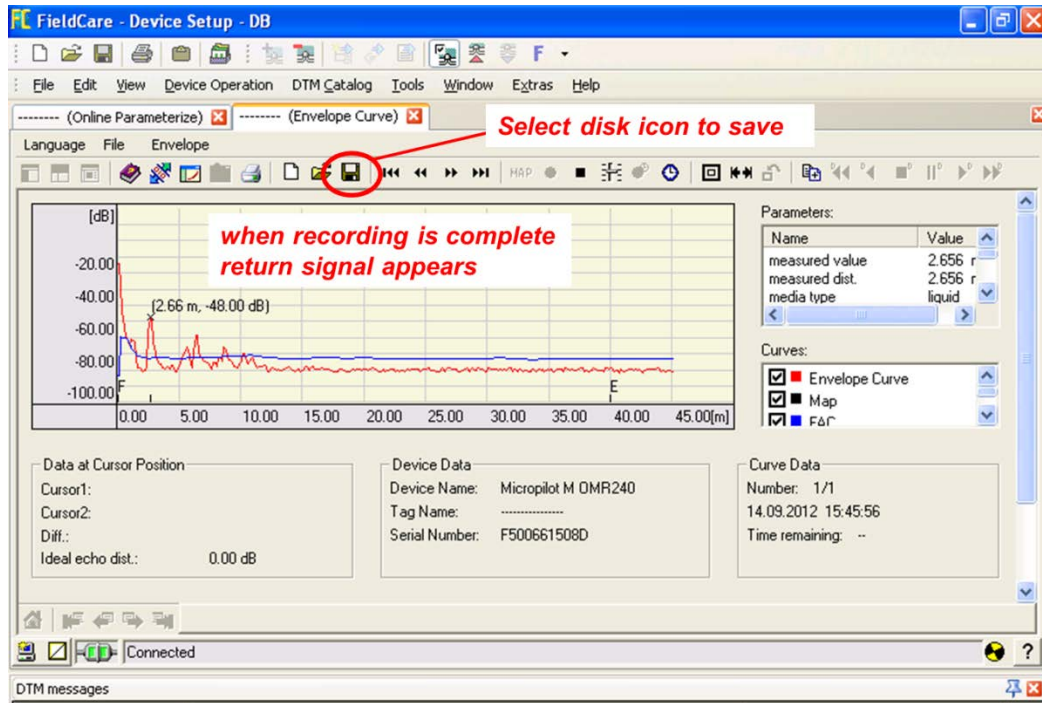

Figure 3-13. Save Envelope Curve

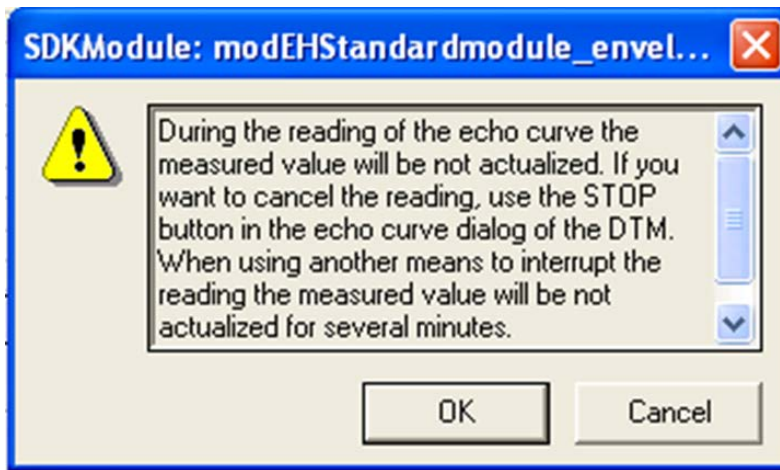

Figure 3-14. If this prompt appears, click OK.

Troubleshooting Envelope Curve Plots

For CO-OPS field applications, the WaterLog[®] sensor's target is the water surface. Compare the range value marked by the X on a target peak in the return signal plot to an approximate measurement of the sensor-to-water distance. The range measurement for reference comparison can be approximate. For example, it can be obtained from a hand-held laser, weighted tape gauge, or a similar device. The main purpose is to confirm that the WaterLog[®] sensor's internal processor is selecting a peak within the return signal that likely provides a reasonable sensor-to-water range.

If the return signal plot indicates that a target peak (marked by X) clearly does not correspond to the range-to-the-water surface (such as the one shown in fig. 3-13), there are several ways the **Envelope Curve** feature can be used to determine the cause of and solution to the problem.

The most common problem from the envelope curve plots is a selected peak in the signal plot that results from a return from some obstruction in the sensor's field of view (commonly referred to as a false echo). A false echo will result in the wrong peak selected with a shorter-than-expected range. If possible, locate the obstruction, (in many cases you can easily see the obstruction) while taking into account the range associated with the incorrectly selected peak of the envelope curve and considering the sensor footprint width at that range, based on values in table 3-1.

If you identify a likely obstruction, reposition the sensor so that the obstruction is no longer in the sensor's field of view. If the sensor repositioning results in a false echo because of an obstruction in the transmission path, repeat steps 1-6 in section 3.4 (pg. 31-33) and then re-examine the envelope curve plot.

If moving the sensor is not an easy option, set the sensor's **blocking distance** parameter to prevent the false echo from being selected as a target. This is only a feasible solution if: (1) the obstruction is higher than the maximum water level expected to occur at a site (for example, near field obstructions, closer to the sensor's horn antenna), and (2) the FC envelope curve plot shows a distinct peak at a further range, beyond the false echo peak that clearly corresponds to the true range to water surface. If this is the case, the **blocking distance** should be set to be greater than the false echo peak but less than the minimum expected sensor to water surface range.

Setting the Blocking Distance Parameter on a WaterLog[®] Sensor

1. From the **Envelope Curve** window, select the **online parameterize** side tab on the FC tool (fig. 3-12). The window shown in fig. 2-5, from which sensor parameters can be set, will be shown again.
2. Under the **extended calibr** group parameter list, select **blocking dist.**

3. In the corresponding labeled entry box on the right, enter a new range value that is approximately 0.5 m greater than the distance of the obstruction indicated in the envelop curve plot.
4. After a new blocking distance is selected, repeat the steps outlined in fig. 3-11 and fig. 3-12 to use the **Envelope Curve** tool to plot a return sample and determine if the return from the water surface is being selected as the target range.

3.5 Interface the WaterLog[®] Sensor and the DCP

Wire the Sensor to the DCP

NOS standard procedure for wiring the WaterLog[®] radar sensor is to connect it to the SDI-12 terminal interface.

The WaterLog[®] sensor's SDI-12 cable consists of four colored wires with the following functions:

- Black:** Ground
- Green:** Ground
- Red:** +12V Power
- White:** SDI-12 Data in/out

Although the specific connection location of SDI cables to each type of Sutron Xpert DCP may vary slightly, the SDI connectors for 12-V power, ground, and data are clearly labeled on all types (marked by the red circle in fig 3-14 a-b).

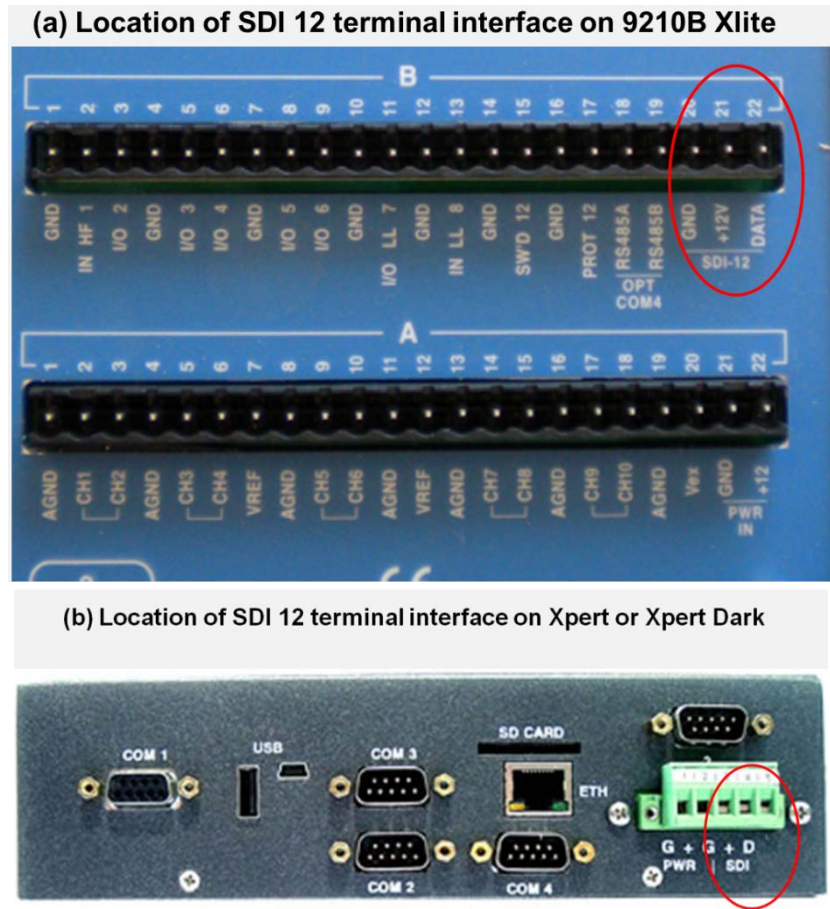

Figure 3-15. SDI-12 term board for (a) 9210B Xlite and (b) Xpert and Xpert Dark.

In most CO-OPS water level station systems, the DCP is integrated into a larger watertight box with a separate SDI-12 terminal board extended down from the DCP itself to allow more room and easy access to the location where the SDI-12 wires need to be connected. The example for a typical CO-OPS system is shown in fig. 3-16. The SDI-12 inputs are the first three wire connection outlets in the terminal board, commonly labeled as 5, 6, and 7 as shown in fig. 3-16.

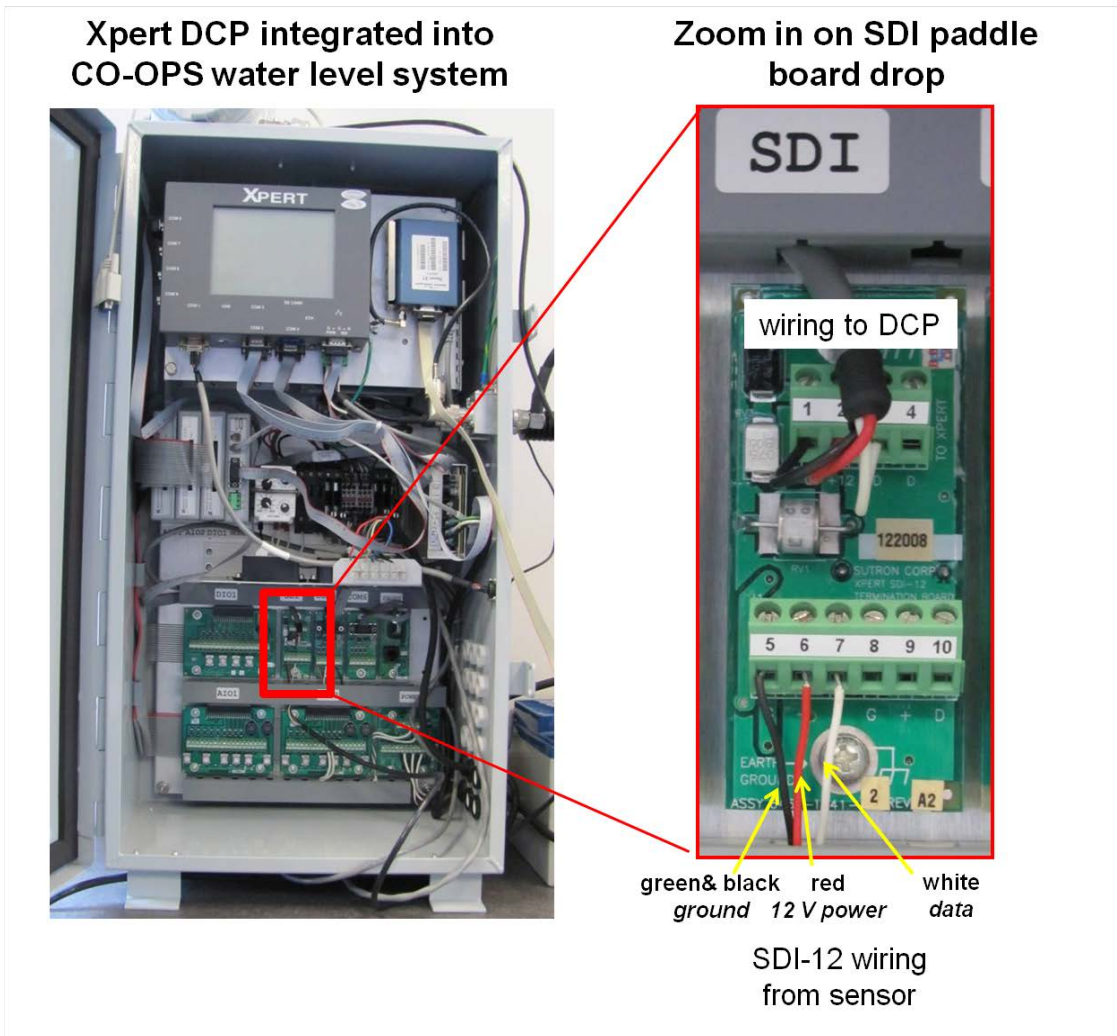

Figure 3-16. SDI-12 terminal board (paddle board) dropped from DCP's SDI 12 panel in typical CO-OPS system.

Xpert Software Setup

Once the sensor is connected to the DCP via SDI-12 interface and the DCP is powered on, the sensor should receive power and turn on.

1. Confirm that the sensor is on by checking its digital readout screen (fig 3-17). After displaying a brief series of initialization messages, the screen should display the radar's measured range value.



Figure 3-17. Radar display screen.

2. Connect the computer to the DCP via an RS232 cable.
3. Start Xterm software on the laptop (fig. 3-18). You may need to change the **COM** port using the drop-down menu on the upper left corner of the GUI (fig. 3-18). If your computer does not have a serial port, use the Windows **Control Panel** to select the correct **COM** port for the **USB** port that has the serial adapter (procedure will vary depending on the specific setup for the PC being used).
4. Set Baud rate to 11520.
5. Under the **Hardware** box, select the **Direct** radio button.
6. Type username and password (provided by CIL/SIL).
7. Click the **Connect** button (fig 3-19).
8. You will be prompted to select from two access types. Click the **Setup Access** button (fig. 3-19).

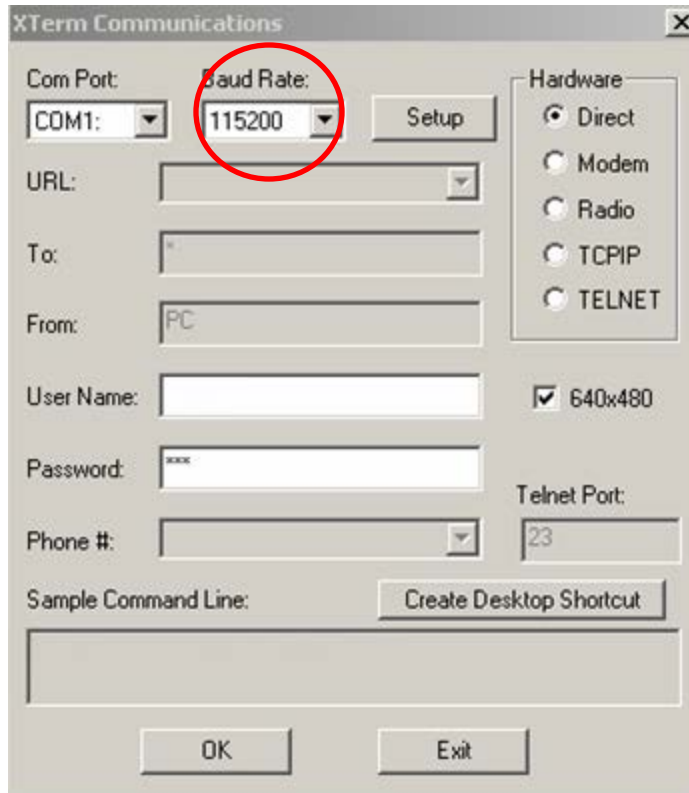

Figure 3-18. Xpert connect screen.

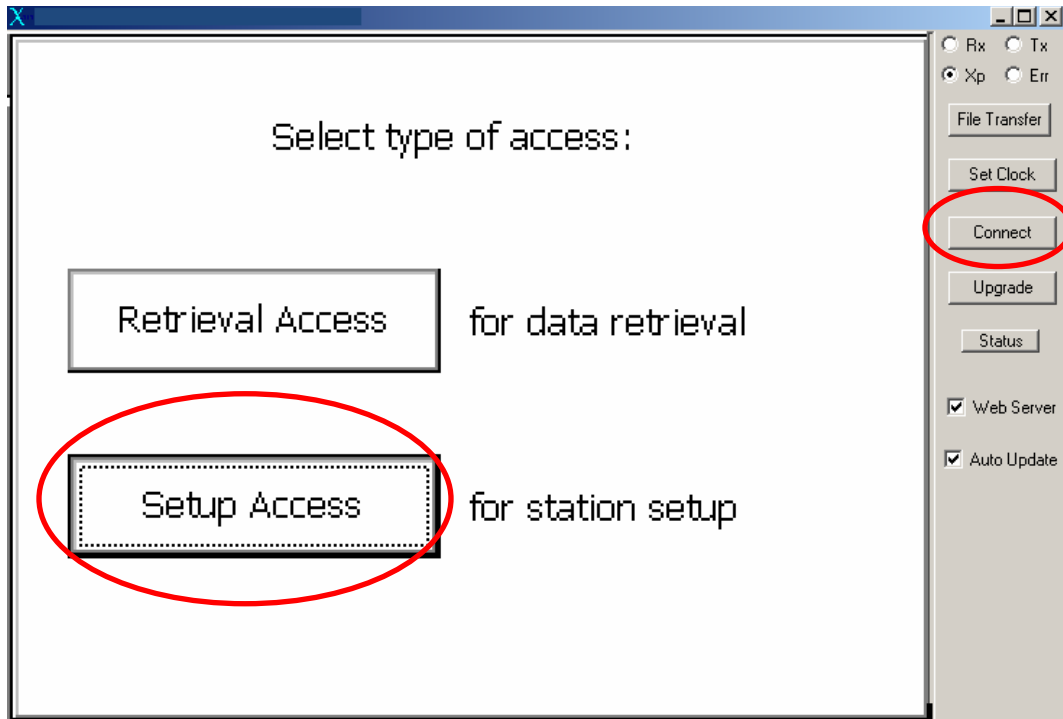

Figure 3-19. Xpert access selection.

9. After the **Setup Access** button is selected, the screen shown in fig. 3-20 will appear.

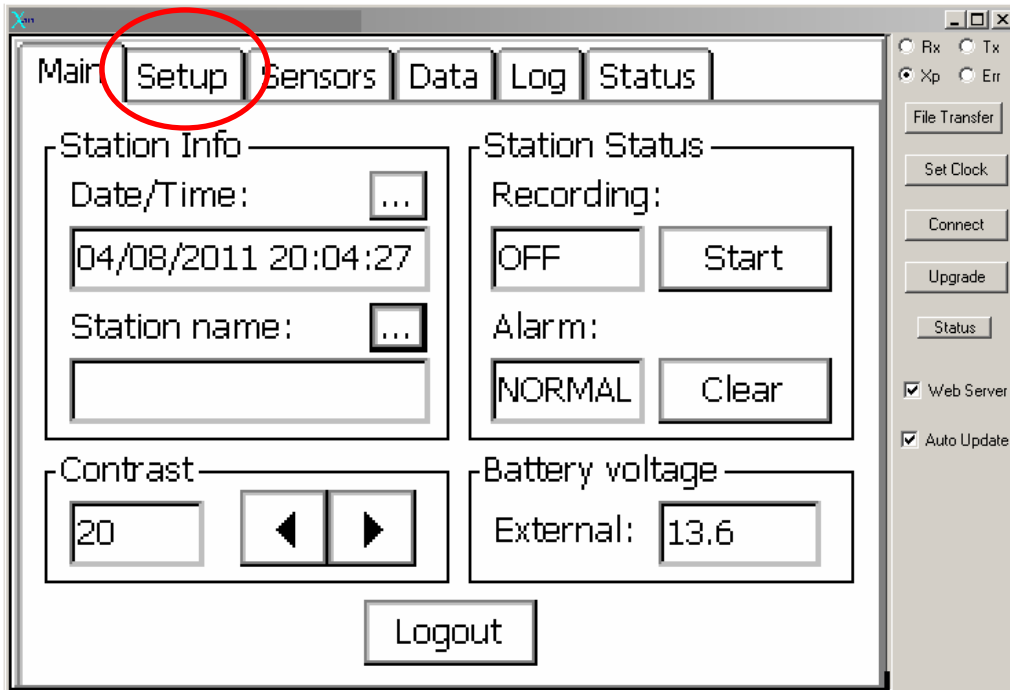

Figure 3-20. Setup Access screen.

Set WaterLog[®] Sensor's SDI-12 Address to 'Y'

Prior to setting up configurations on the DCP for integration of a WaterLog[®] sensor, use the DCP interface to set the WaterLog[®]'s SDI-12 address to 'Y.'

1. Select the **Sensors** tab and then click the **SDI-12** button (fig. 3-21).
2. Assuming the sensor's default address is **0**, select **0** in the address drop-down box, and then type **AY** in the command drop-down box (fig. 3-22). Click the **Send** button.
3. If the sensor's address is successfully changed to 'Y,' the value will be displayed after the **AY** command is issued, as shown on fig. 3-23.

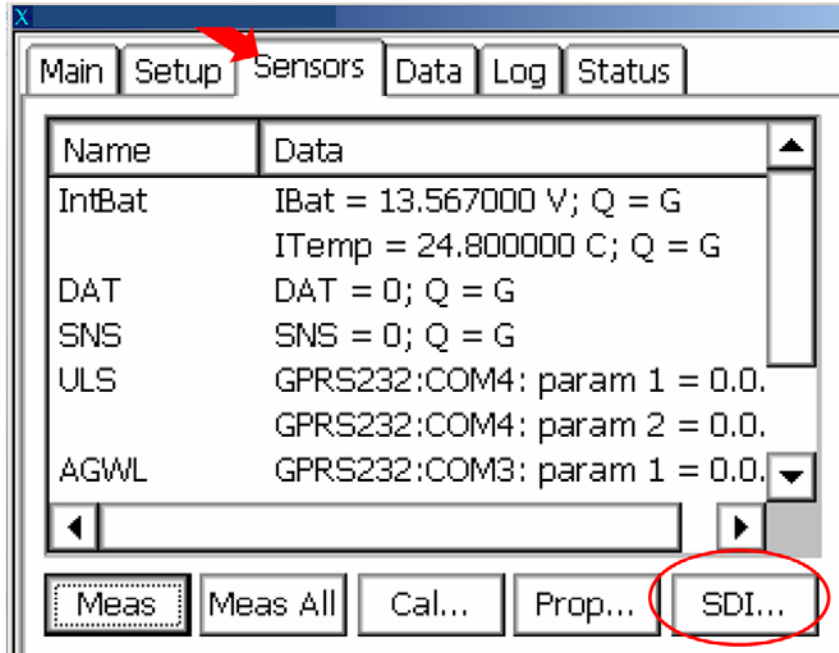

Figure 3-21. Select Sensors, then click SDI.

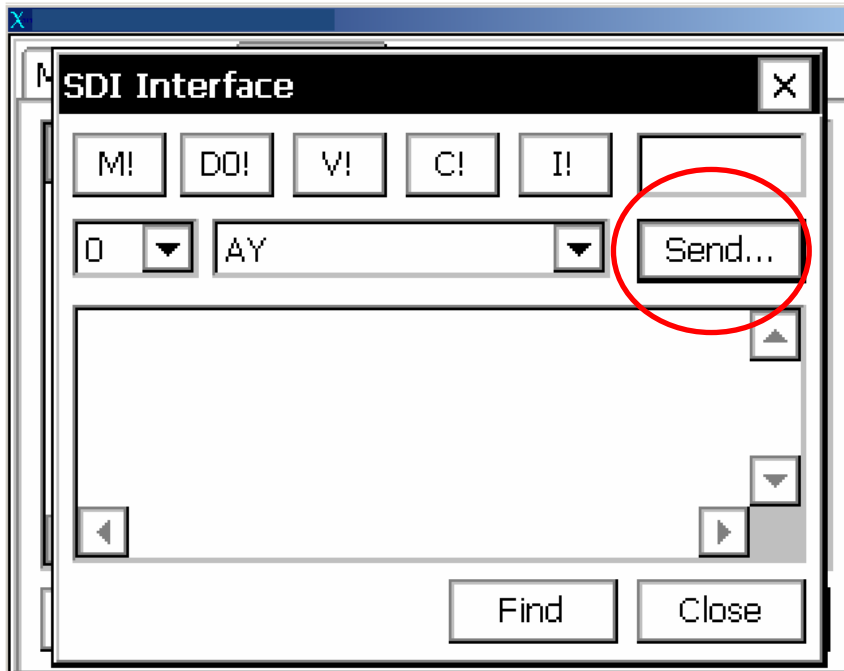

Figure 3-22. Type AY in the drop-down box.

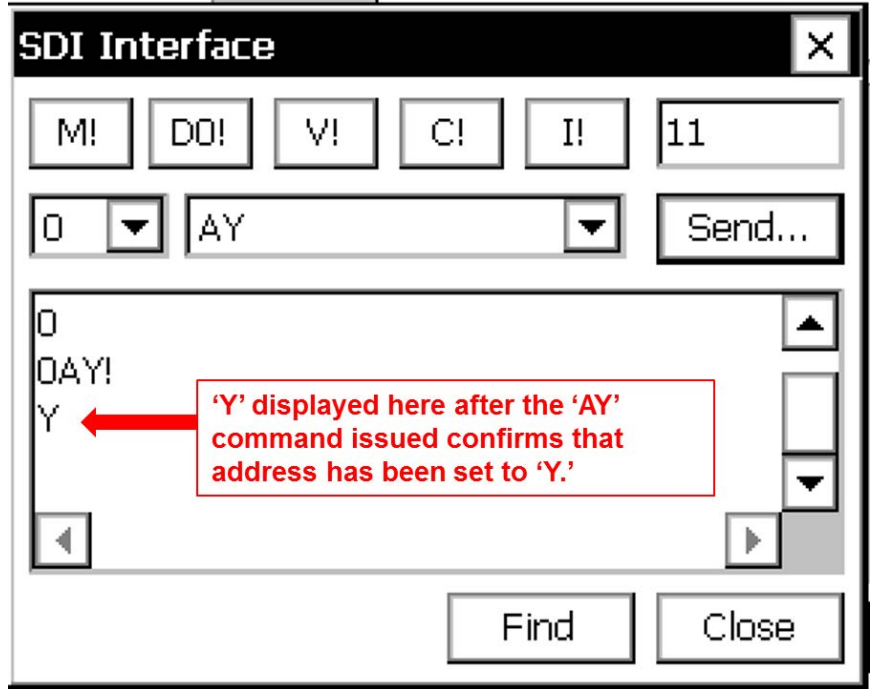

Figure 3-23. Value 'Y' displayed after AY command issued.

Set WaterLog[®] Sensor's Power Mode to 'Fast Measure'

After the WaterLog[®]'s SDI-12 address is set to 'Y,' use the same 'SDI Interface' Xpert GUI window to set the sensor's power mode to '1,' which translates to 'Fast Measure' mode. For further details on sensor power mode options, refer to section 3-15 of the Waterlog[®] H3611 User's Manual [1].

1. Make sure that **Y** is selected in the address drop-down box, and then type in the command to read the current power setting, '**XRPM.**' (fig. 3-24). Click the **Send** button.
2. Next, click the '**DO!**' button to display the power mode setting that has been read (fig. 3-25). If '**0**' is displayed, then the power mode is set to '**Sleep**' and it needs to be changed. If '**1**' is displayed, then the sensor's power mode is already configured to '**Fast Measure**' and can be left as is.
3. If the returned sensor power mode setting is '**0**' as shown in fig 3-25, set the power mode to '**1**' by typing the command '**XWPM1**' and then click the '**Send**' button (fig. 3-26).
4. After the '**XWPM1**' command is sent, click the '**DO!**' button to display the power mode setting and confirm that it has been set to '**1**'

(fig. 3-27). Once the proper power mode setting is confirmed, click the **Close** button in the lower right corner of the **SDI Interface** window.

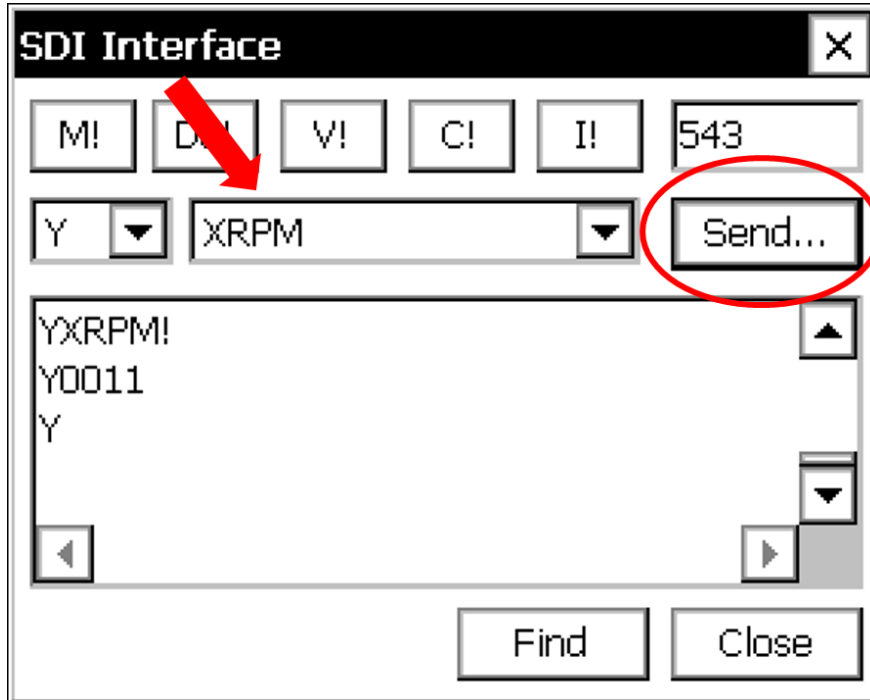

Figure 3-24. Type XRPM and click Send.

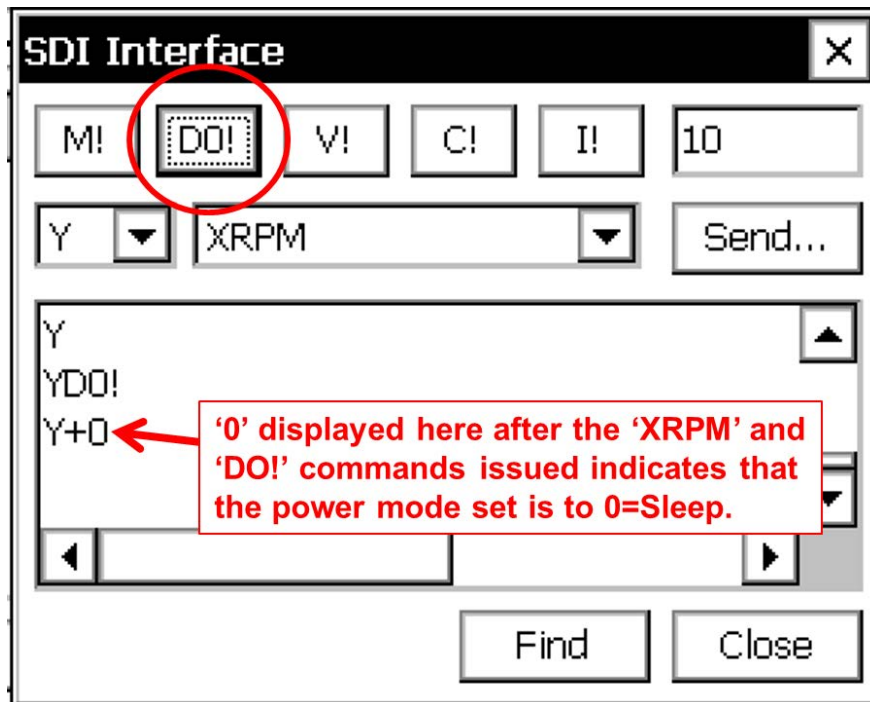

Figure 3-25. Click DO! to display power mode.

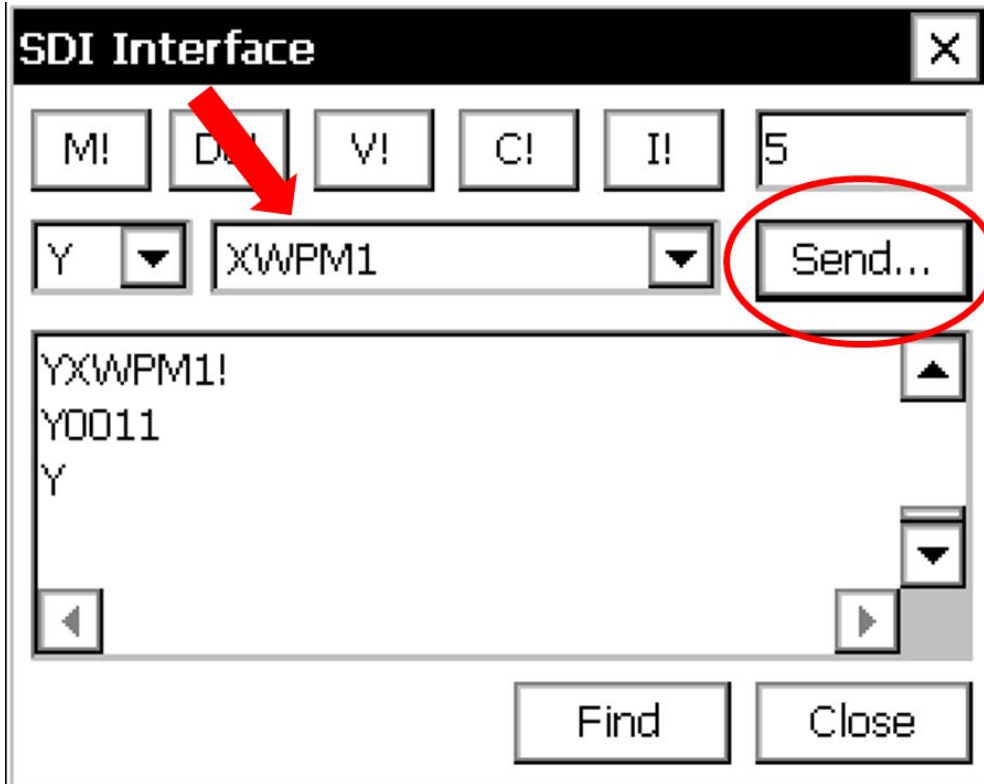

Figure 3-26. Type XWPM1 and then click Send.

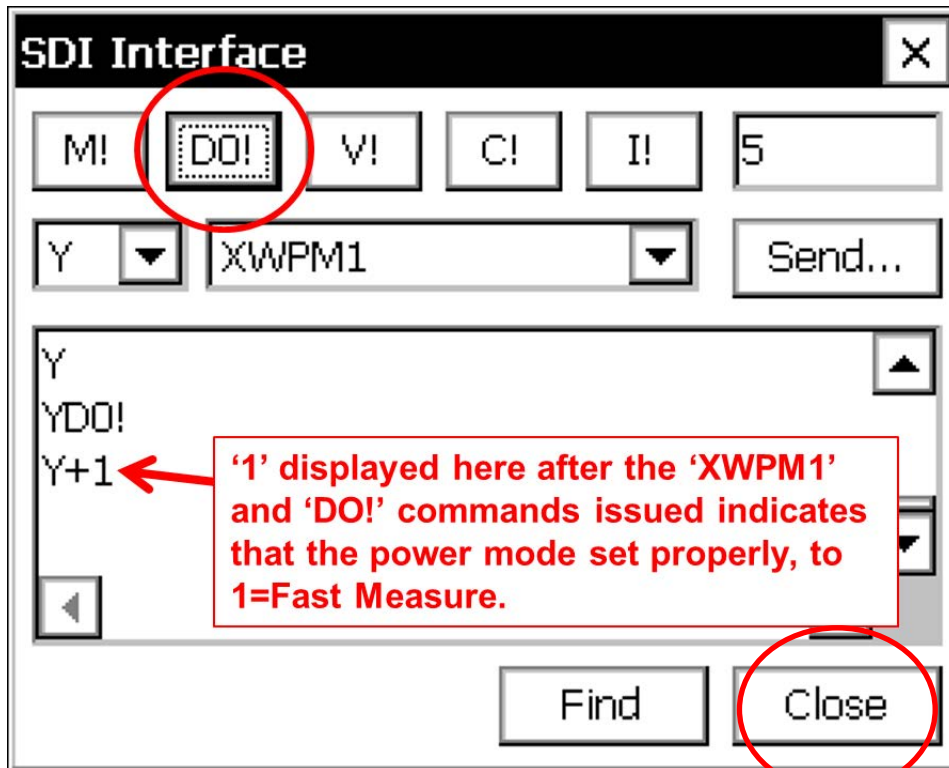

Figure 3-27. Click DO! and then click Close.

NOTE: In most cases, by the time a WaterLog[®] sensor and DCP are sent to the field, either CO-OPS CIL or SIL has configured all DCP setups. Figure 3-23 illustrates the final graphical setup for a WaterLog[®] sensor that was previously configured by CIL or SIL. However, if the graphical setup must be programmed on the DCP, steps required for the graphical setup for a WaterLog[®] radar sensor can be found in appendix A. If the interface is already configured, the only thing needed to complete the field installation is to start sensor recording and confirm that the sensor is recording and transmitting data. Both steps are described in the following paragraphs.

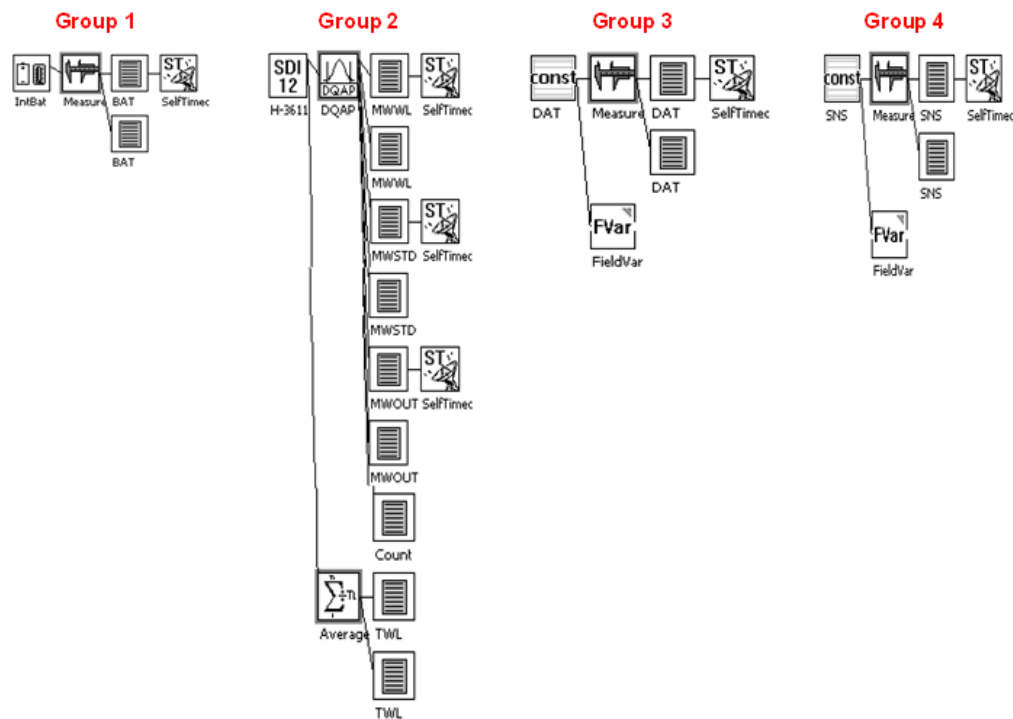

Figure 3-28. Final graphical setup for a WaterLog[®] sensor, which is configured by CIL/SIL prior to deployment.

Start Recording Data

After connecting the sensor to the DCP via SDI-12 interface, make sure the DCP and sensor are powered on. To start recording, connect to the DCP via laptop and the Xterm interface:

1. In Xterm, return to the **Main** tab under the **Setup Access**. Click the **Start** button (shown in fig. 3-24); the hour glass icon will appear, and it may take a minute or two for recording to start.

- Once the **Recording** text box next to the start button reads **ON**, the sensor should be recording.

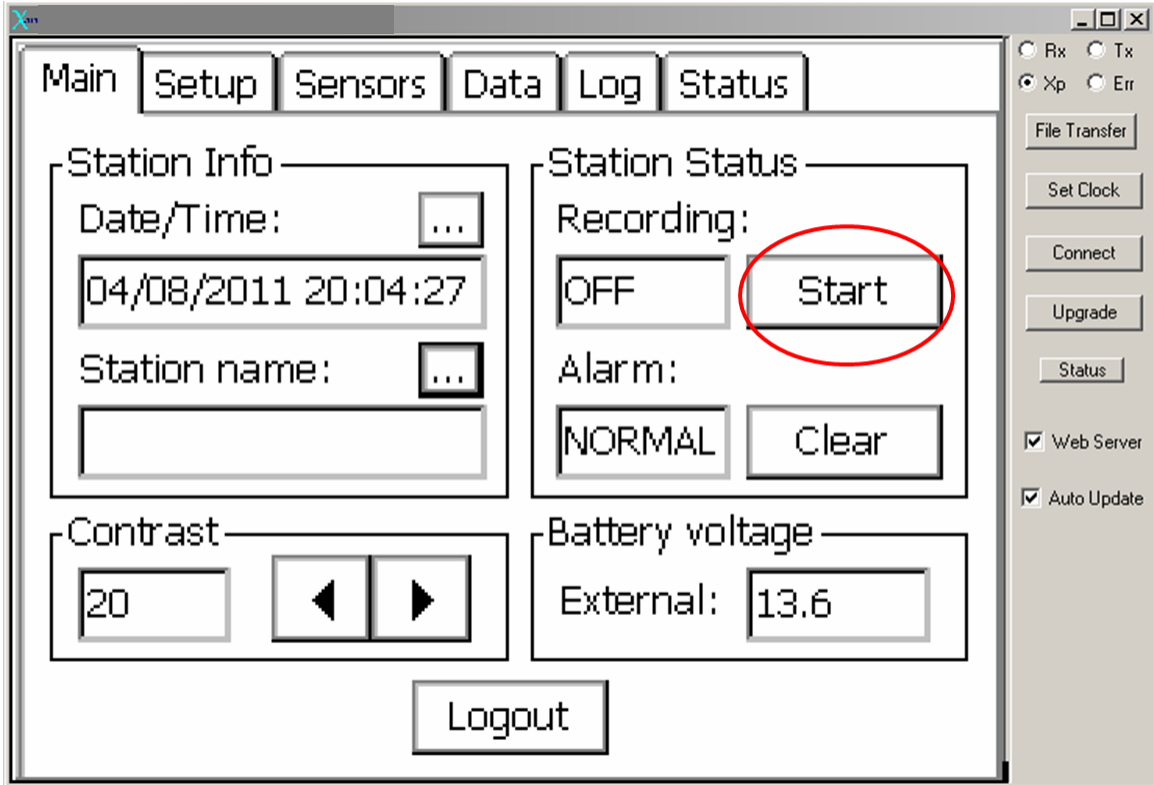

Figure 3-29. Start sensor recording.

Confirm that Data Are Being Recorded and Transmitted

Once you have completed all of the previous procedures and steps, the WaterLog[®] sensor should be installed and recording to the DCP. The final portion of the installation process involves conducting a few checks to ensure that the sensor/DCP system is recording and transmitting 6-minute real-time data. These checks involve viewing the 1-Hz log file on the DCP, calling the CIL or SIL to request a real-time transmission confirmation, checking the *DiagTool* display to confirm real-time transmission and ingestion of data (this can only be completed by CO-OPS personnel due to limited tool access), and checking the system’s PORTS[®] tag.

Check 1-Hz Log File

After starting the sensor recording, check the 1-Hz Flash Disk log file to confirm that the sensor is measuring realistic range-to-water values and that data are being recorded to the DCP log files.

- In the Xterm’s **Setup Access** screen shown in fig. 3-25, select the **Log** tab under **Setup Access**. The screen in fig. 3-26 will appear.

2. Use the **Select Log:** drop-down menu shown in fig. 3-26 to select the 1-Hz log (**MWWL_1Hz.log**) on Flash Disk.
3. Once the **Flash Disk\ MWWL_1Hz.log** is selected, raw 1 Hz data being recorded by the microwave wave radar sensor should be displayed in the window above the drop-down menu as shown in fig. 3-26. Confirm that reasonable range-to-water surface values are being measured and that values are being updated at a 1-Hz rate in the display window.
4. Close the log by clicking the **Close** button (lower right, fig. 3-26), go back to the **Main** tab, and log out of the DCP. Close Xterm and disconnect the laptop-to-DCP cable.

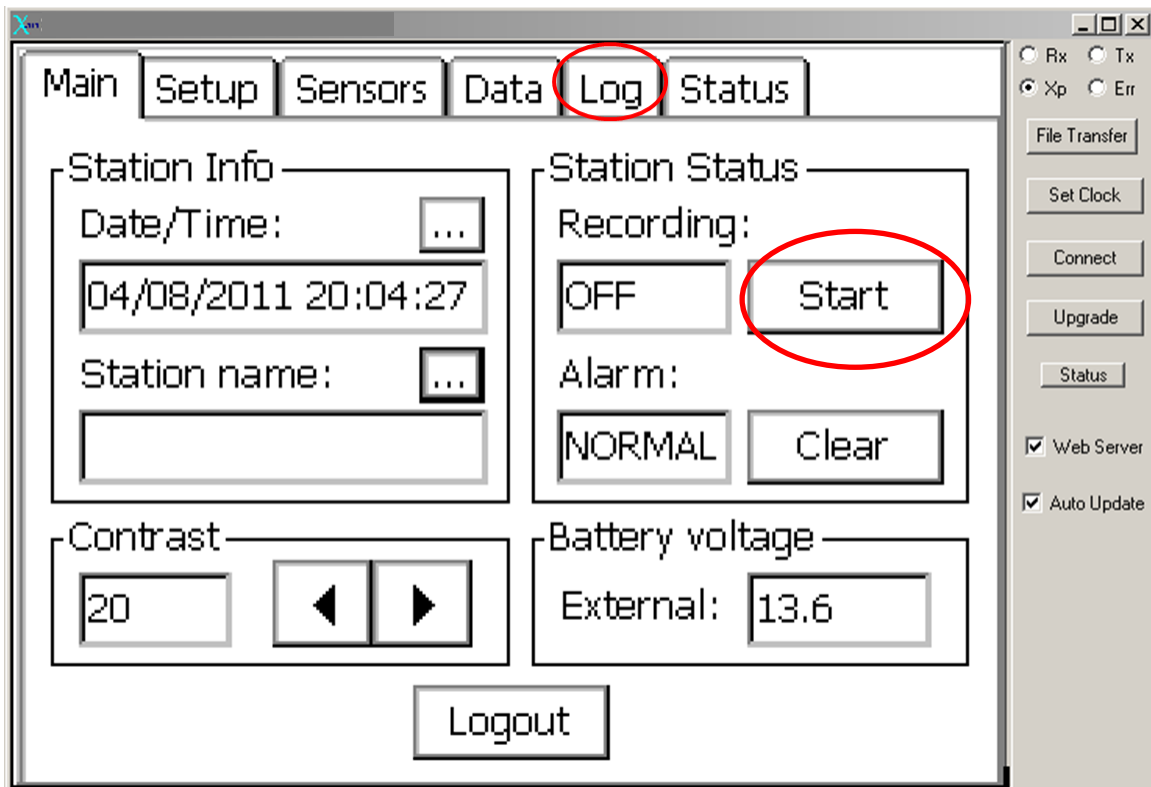

Figure 3-30. Select Log tab.

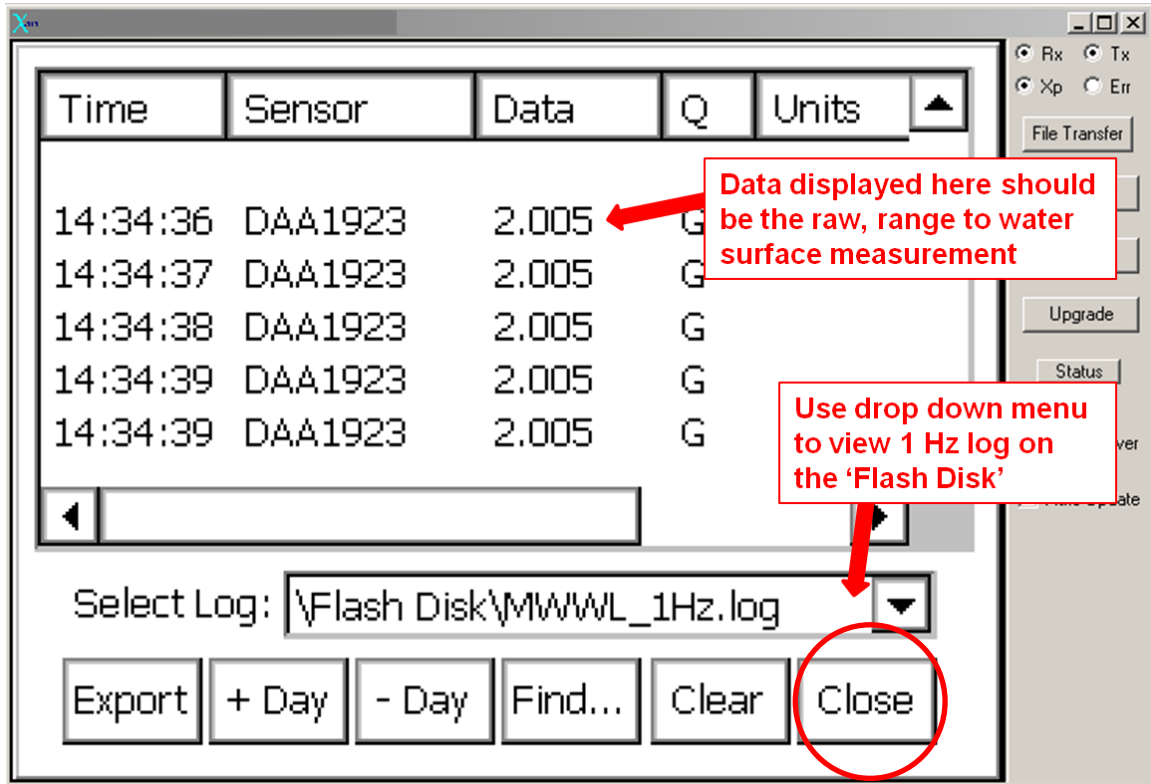

Figure 3-31. Confirm that data are being recorded.

Call CIL or SIL to Confirm Transmission of Real-time Data

As mentioned in section 3.1, contact the CIL or SIL team lead one week prior to the installation to arrange a POC to be available after the installation.

After the installation is complete, contact the identified CIL/SIL POC and request that s/he confirm that the sensor data are being transmitted and ingested. Have the following information ready to provide when calling:

- Station ID
- GOES ID
- IP modem address
- Station location, name, and approximate latitude/longitude

Check *Diagtool* to Confirm Transmission of Real-time Data (can only be accessed by CO-OPS personnel)

The CO-OPS *DiagTool* can be used to conduct an additional confirmation of real-time data transmission. However, non-CO-OPS personnel cannot obtain the required username and password to access this tool. So, if the installer is not a CO-OPS employee, this step may be skipped. If the installer is a CO-OPS employee with a login, perform the following steps:

1. Open the Diag Tool
2. Enter the appropriate group login and password when prompted; the page shown in fig. 3-27 will appear.
3. Enter the station number as shown in fig. 3-27.
4. Select begin and end dates that cover some period after the installation was completed and data recording started and then click the **Get Plots** button.
5. A plot will be generated as shown in fig. 3-28. If data are displayed, then they are being transmitted and ingested.

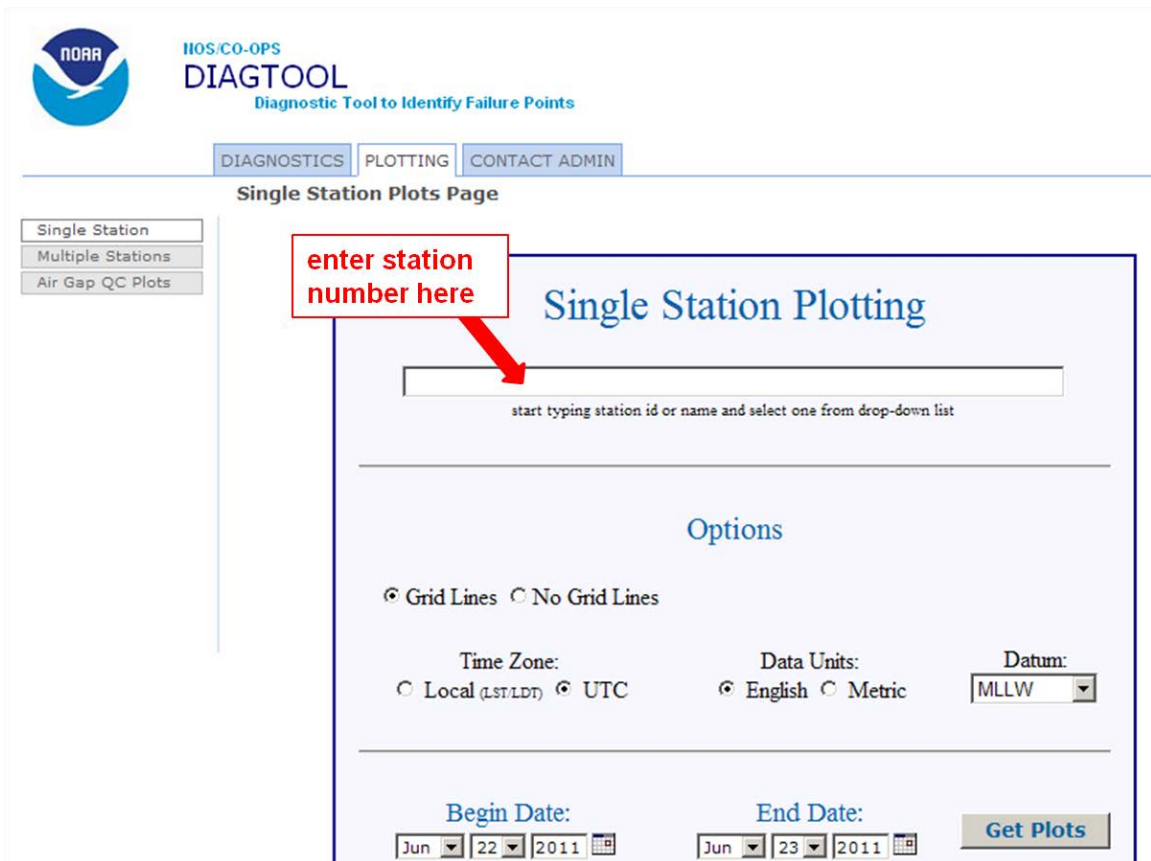

Figure 3-32. *DiagTool* main plotting page.

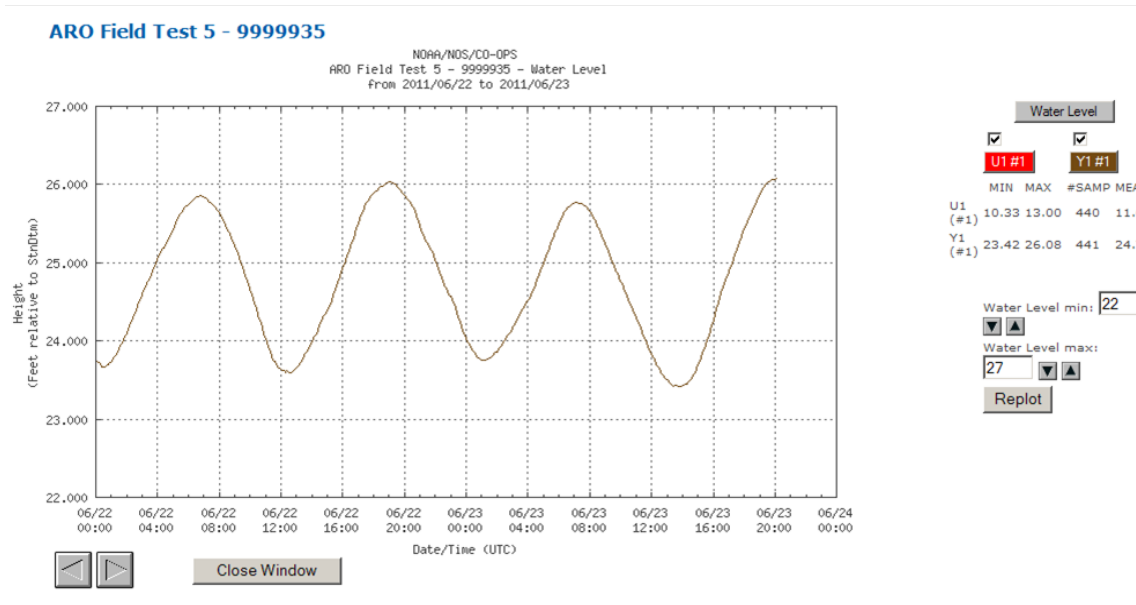

Figure 3-33. DiagTool plot.

Get PORTS[®] Tag from the DCP

To get PORTS[®] data from the DCP:

1. Using a computer, run Procomm or some other terminal emulator (such as Hyperterm), setting the **COM** port of the computer to 9600-N-8-1.
2. Press **ESC**. You will get the login/password prompts.
3. After logging in, you should now see the following:

```
NOS 99999721 04/07/2011 17:00:00
Y1 8 1.627 0.005 0
L1 < 13.8
DAT 10.513
SNS -0.004
```

Table 3-2 shows an interpretation of each line in the PORTS[®] data file.

Table 3-2. Line-by-line interpretation of PORTS[®] data file.

Line 1	
NOS	National Ocean Service
99999721	Station Number Elizabeth River MWWL Test site
04/07/2011	Date
17:00:00	Data collection time. PORTS data is reported every six minutes starting at six minutes after the hour. This is NOT the station time or date.
Line 2	
Y1 8	Denotes MWWL data. Y = MWWL Data 1 = 1st MWWL sensor at this station (= MWWL GOES flag
1.627	MWWL data in meters (m). The water is 1.627 m from the zero point of the sensor.
0.005	Standard deviation
0.00	Outlier count
Line 3	
L1 <	Denotes DCP battery voltage Y= DCP battery voltage 1= 1 st DCP battery voltage at this station <= DCP battery voltage GOES flag
13.8	DCP battery voltage
Line 4	
DAT	Station datum offset.
10.513	Offset value
Line 5	
SNS	Sensor offset.
-0.004	Offset value

Once all steps described above are complete and it is confirmed that the sensor is measuring reasonable range-to-water values and transmitting real-time data, the installation is complete. Prior to leaving the site, personnel should double check that the 6-minute values being recorded to the DCP reasonably match the range values on the sensor's display screen.

References

1. Design Analysis Associates, Inc. WaterLog® Series Model H3611i SDI-12 Radar Water Level Sensor User's Manual, Version 1.2. (<http://www.waterlog.com>) Available in the 'Resource Library,' which can be accessed by selecting 'Support' from the WaterLog® home page.
2. Endress + Hauser. FieldCare Package Version 1.19.00
<http://www.endress.com/eh/home.nsf/#products/dtm-download>

Appendix A

How to Configure the DCP Graphical Setup for a Design Analysis WaterLog® Sensor

By Bob Heitsenrether
May 2012
Version 1.0

The following appendix describes how to configure the Xpert software setups on the DCP for the Waterlog® radar sensor using the Xpert's **Graphical Setup Tool**. To access the **Graphical Setup Tool**: (1) go to **Setup Access**, (2) select the **Setup** tab, (3) select **Graphical Setup** from the list, and (4) select the **Edit** button.

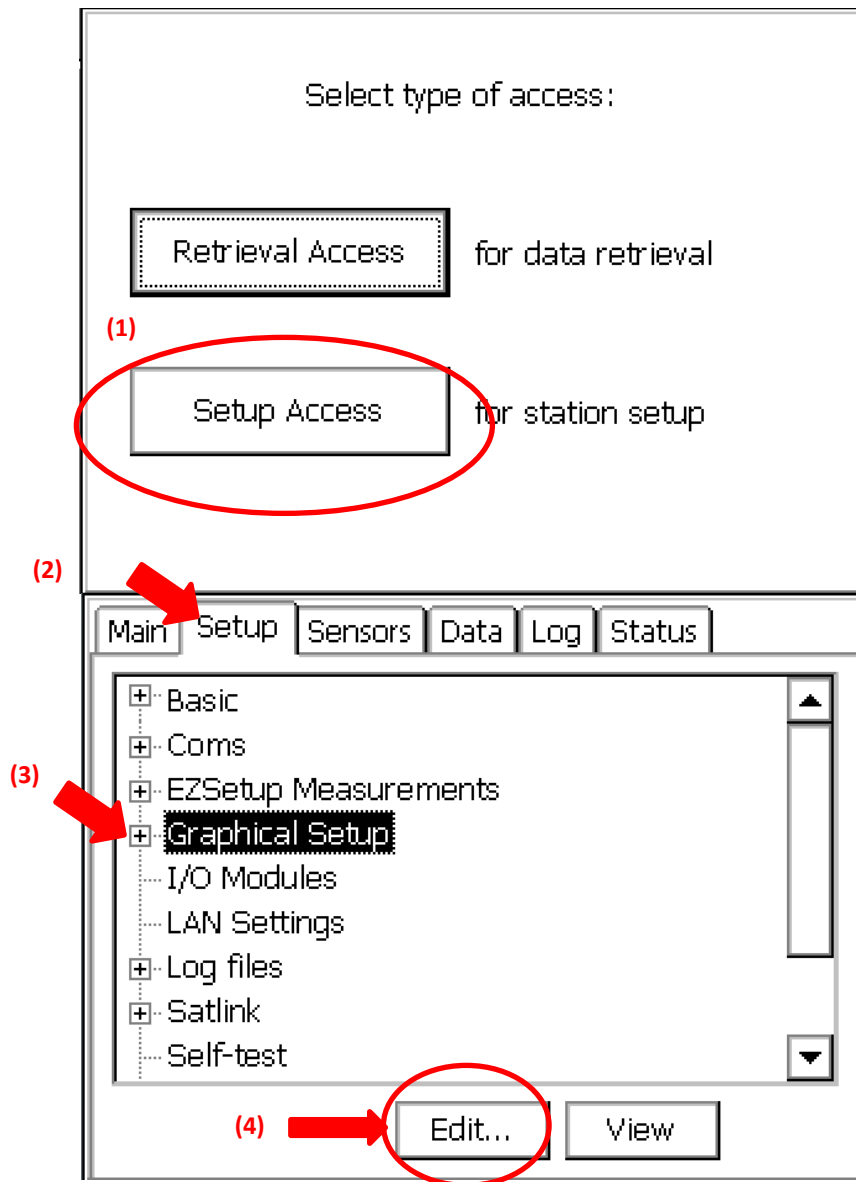

Microwave Radar Water Level Sensor Field Installation Guide

After starting a new **Graphical Setup**, the DCP setups for the Waterlog[®] radar can be configured by adding a series of graphical objects, or 'blocks' and then 'wiring' them together using the **Graphical Setup Tool**. From a new graphical setup window, new blocks can be added by (1) selecting the **add** button and (2) selecting a block **category type**. After parameters are set for each block, the blocks can be connected using the **wire** button.

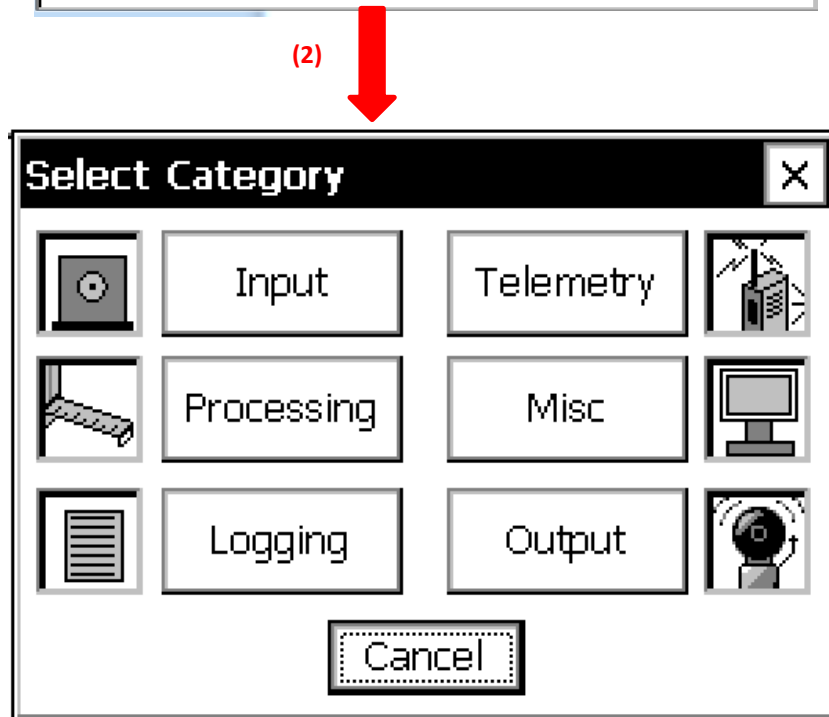
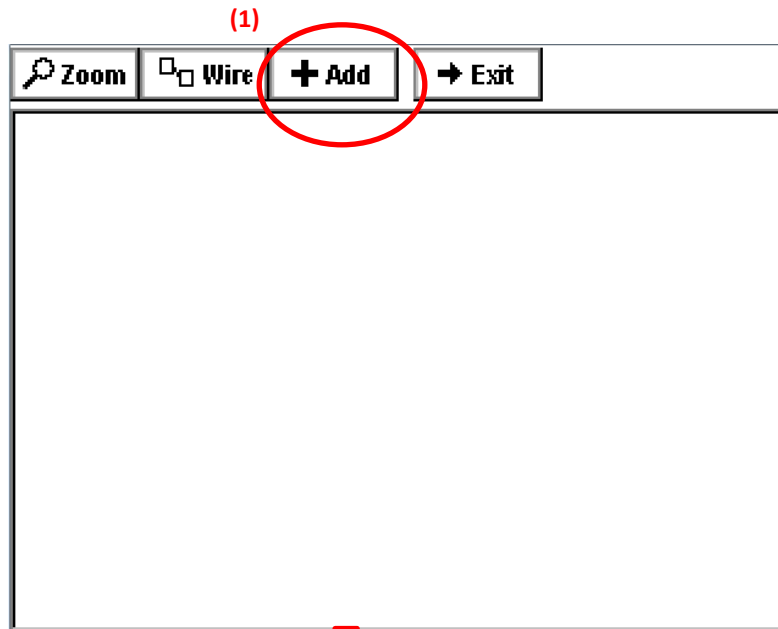

The Xpert graphical setup for the Waterlog® radar sensor consists of 4 groups of blocks that are wired together. The following series of diagrams shows each group of wired blocks and then displays the property settings for each.

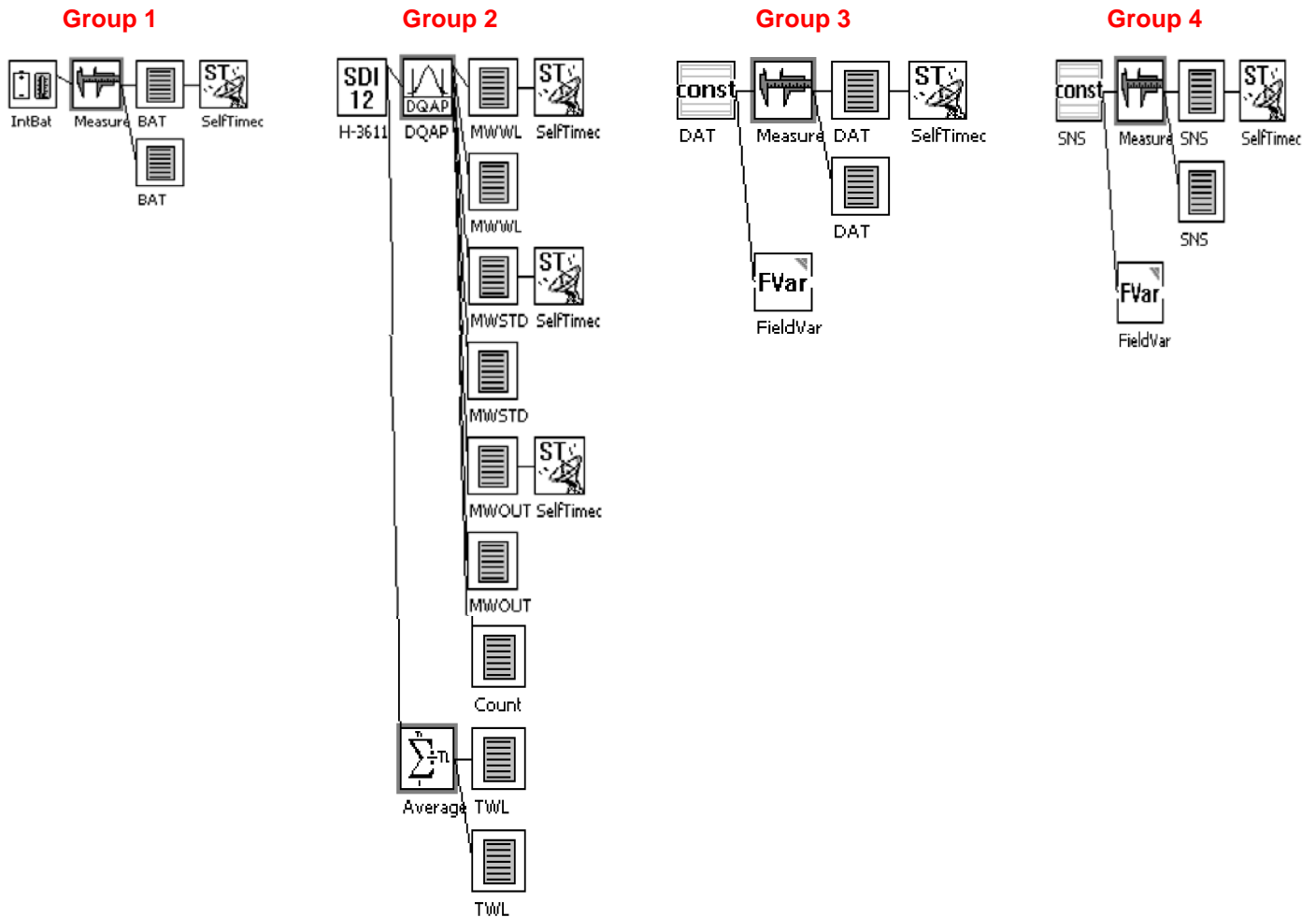

Group 1 – Wired Block Diagram and Individual Block Properties

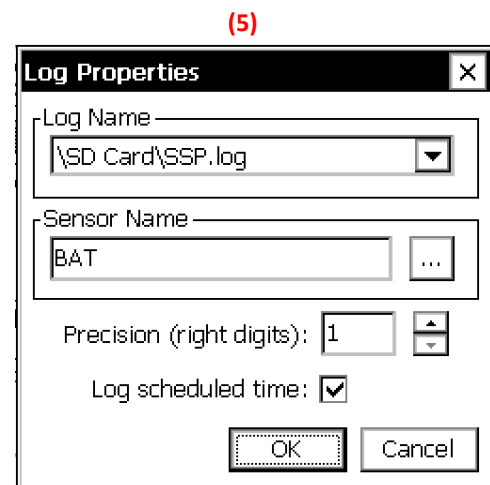
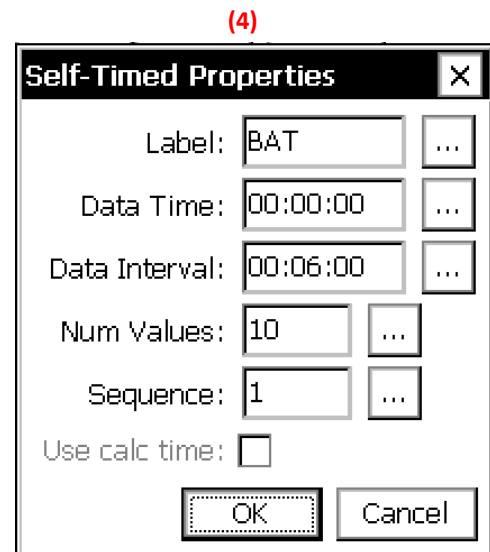
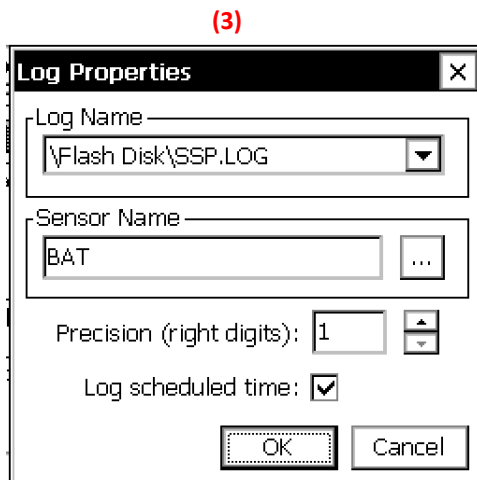
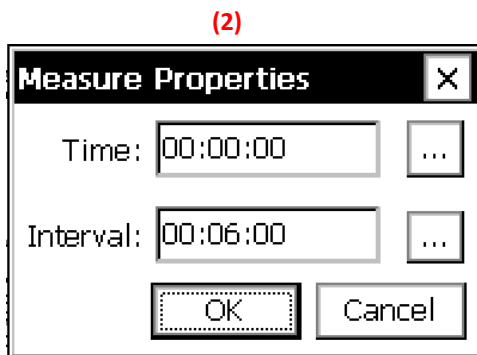
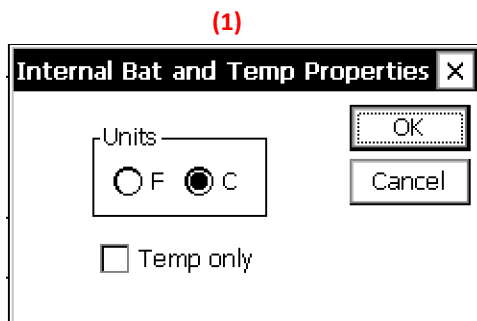
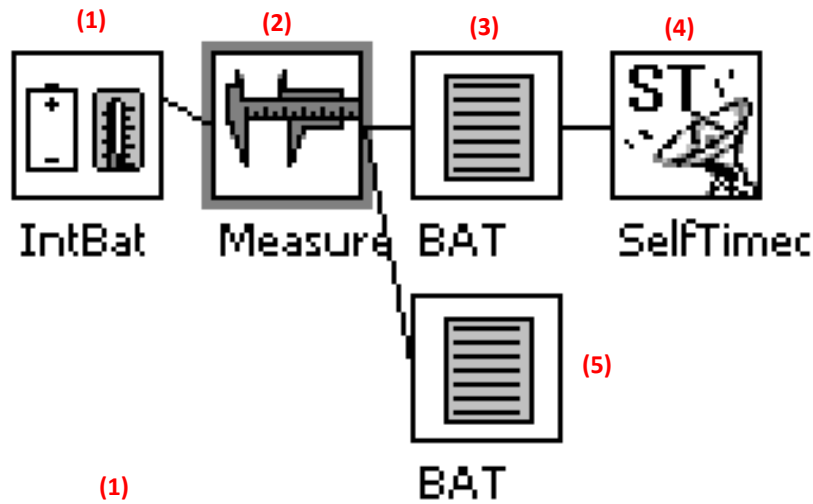

Group 2 – Wired Block Diagram and Individual Block Properties

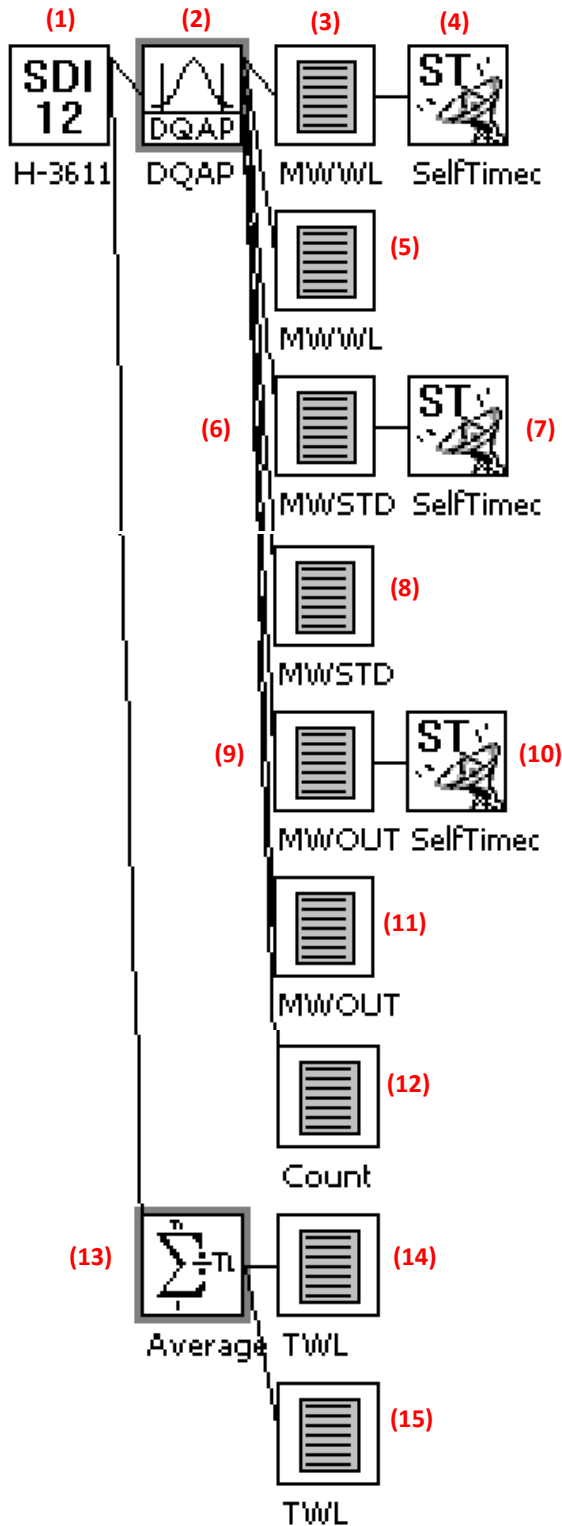

SDI Properties

Address: Y [OK] [Cancel]

Command: M [...]

Slope: -1 [...]

Offset: 0 [...]

Units: Meters [...]

(2)

DQAP Average Properties

Schedule

Time: 00:03:01 [...]

Interval: 00:06:00 [...]

Sample

Interval: 00:00:01 [...]

Duration: 00:06:00 [...]

[OK] [Cancel]

(3)

Log Properties

Log Name: \Flash Disk\SSP.LOG [...]

Sensor Name: MWWL [...]

Precision (right digits): 3 [...]

Log scheduled time:

[OK] [Cancel]

(4)

Self-Timed Properties

Label: MWWL [...]

Data Time: 00:03:00 [...]

Data Interval: 00:06:00 [...]

Num Values: 40 [...]

Sequence: 1 [...]

Use calc time:

[OK] [Cancel]

(5)

The screenshot shows the 'Log Properties' dialog box. The 'Log Name' dropdown menu is set to '\SD Card\SSP.log'. The 'Sensor Name' text box contains 'MWWL'. The 'Precision (right digits)' spinner is set to 3. The 'Log scheduled time' checkbox is checked. The 'OK' button is highlighted with a dashed border.

(6)

The screenshot shows the 'Log Properties' dialog box. The 'Log Name' dropdown menu is set to '\Flash Disk\SSP.LOG'. The 'Sensor Name' text box contains 'MWSTD'. The 'Precision (right digits)' spinner is set to 3. The 'Log scheduled time' checkbox is checked. The 'OK' button is highlighted with a dashed border.

(7)

The screenshot shows the 'Self-Timed Properties' dialog box. The 'Label' text box contains 'MWSTD'. The 'Data Time' spinner is set to 00:03:00. The 'Data Interval' spinner is set to 00:06:00. The 'Num Values' spinner is set to 30. The 'Sequence' spinner is set to 1. The 'Use calc time' checkbox is unchecked. The 'OK' button is highlighted with a dashed border.

(8)

The screenshot shows the 'Log Properties' dialog box. The 'Log Name' dropdown menu is set to '\SD Card\SSP.log'. The 'Sensor Name' text box contains 'MWSTD'. The 'Precision (right digits)' spinner is set to 3. The 'Log scheduled time' checkbox is checked. The 'OK' button is highlighted with a dashed border.

(9)

The screenshot shows the 'Log Properties' dialog box. The 'Log Name' dropdown menu is set to '\Flash Disk\SSP.LOG'. The 'Sensor Name' text box contains 'MWOUT'. The 'Precision (right digits)' spinner is set to 0. The 'Log scheduled time' checkbox is checked. The 'OK' button is highlighted with a dashed border.

(10)

The screenshot shows the 'Log Properties' dialog box. The 'Log Name' dropdown menu is set to '\Flash Disk\SSP.LOG'. The 'Sensor Name' text box contains 'MWOUT'. The 'Precision (right digits)' spinner is set to 0. The 'Log scheduled time' checkbox is checked. The 'OK' button is highlighted with a dashed border.

(11)

The screenshot shows a dialog box titled "Log Properties" with a close button (X) in the top right corner. It contains the following fields and controls:

- Log Name:** A dropdown menu showing "\SD Card\SSP.log".
- Sensor Name:** A text input field containing "MWOUT" and a browse button (...).
- Precision (right digits):** A numeric input field with the value "0" and up/down arrow buttons.
- Log scheduled time:** A checked checkbox.
- Buttons:** "OK" and "Cancel" buttons at the bottom.

(14)

The screenshot shows a dialog box titled "Log Properties" with a close button (X) in the top right corner. It contains the following fields and controls:

- Log Name:** A dropdown menu showing "\Flash Disk\TSU1MIN.log".
- Sensor Name:** A text input field containing "TWL" and a browse button (...).
- Precision (right digits):** A numeric input field with the value "3" and up/down arrow buttons.
- Log scheduled time:** A checked checkbox.
- Buttons:** "OK" and "Cancel" buttons at the bottom.

(12)

The screenshot shows a dialog box titled "Log Properties" with a close button (X) in the top right corner. It contains the following fields and controls:

- Log Name:** A dropdown menu showing "\Flash Disk\SSP.LOG".
- Sensor Name:** A text input field containing "Count" and a browse button (...).
- Precision (right digits):** A numeric input field with the value "0" and up/down arrow buttons.
- Log scheduled time:** A checked checkbox.
- Buttons:** "OK" and "Cancel" buttons at the bottom.

(15)

The screenshot shows a dialog box titled "Log Properties" with a close button (X) in the top right corner. It contains the following fields and controls:

- Log Name:** A dropdown menu showing "\SD Card\TSU1MIN.log".
- Sensor Name:** A text input field containing "TWL" and a browse button (...).
- Precision (right digits):** A numeric input field with the value "3" and up/down arrow buttons.
- Log scheduled time:** A checked checkbox.
- Buttons:** "OK" and "Cancel" buttons at the bottom.

(13)

The screenshot shows a dialog box titled "Average Properties" with a close button (X) in the top right corner. It contains the following fields and controls:

- Schedule:**
 - Time:** A time input field showing "00:00:00" and a browse button (...).
 - Interval:** A time input field showing "00:01:00" and a browse button (...).
- Sample:**
 - Interval:** A time input field showing "00:00:01" and a browse button (...).
 - Duration:** A time input field showing "00:01:00" and a browse button (...).
- Buttons:** "OK" and "Cancel" buttons on the right side.

Group 3 – Wired Block Diagram and Individual Block Properties

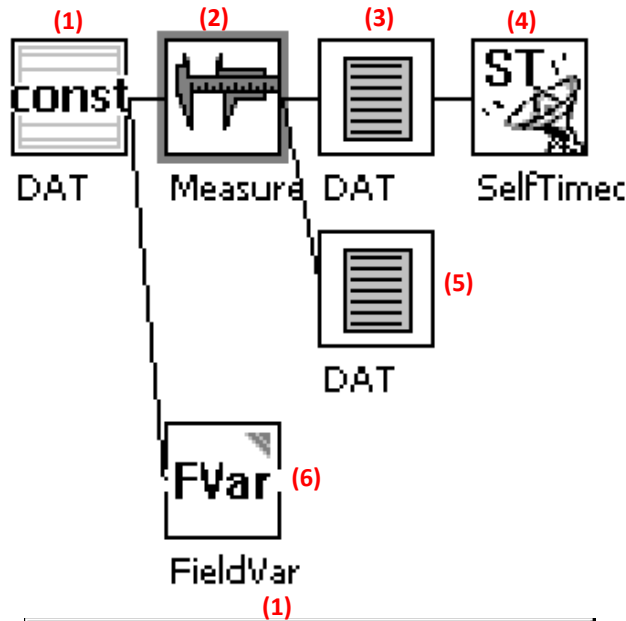

(4) Self-Timed Properties

Label:

Data Time:

Data Interval:

Num Values:

Sequence:

Use calc time:

(1) Constant Properties

Constant:

Test

(5) Log Properties

Log Name:

Sensor Name:

Precision (right digits):

Log scheduled time:

(2) Measure Properties

Time:

Interval:

(6) Log Properties

Log Name:

Sensor Name:

Precision (right digits):

Log scheduled time:

(6) Select Field Variables

Internal Name	Public Name
<input checked="" type="checkbox"/> Constant	DAT
<input type="checkbox"/> Units	
<input type="checkbox"/> UseUnits	
<input type="checkbox"/> TestFlag	

Group 4 – Wired Block Diagram and Individual Block Properties

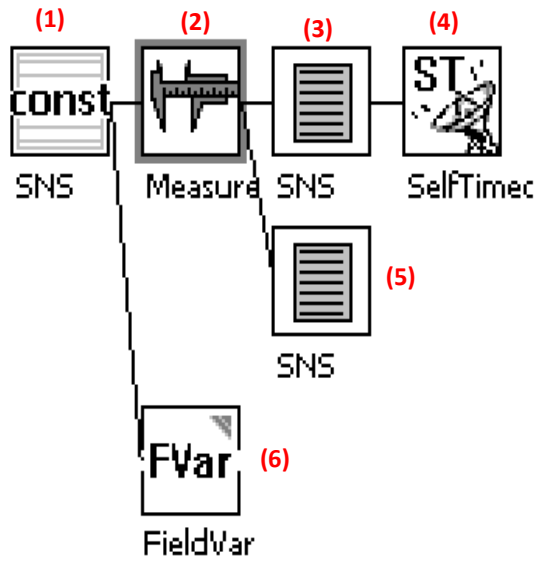

(3)

Log Properties

Log Name: \Flash Disk\SSP.LOG

Sensor Name: SNS

Precision (right digits): 3

Log scheduled time:

OK Cancel

(1)

Constant Properties

Constant: 0.004

Test

OK Cancel Units...

(2)

Measure Properties

Time: 00:00:00

Interval: 00:06:00

OK Cancel

(4)

Self-Timed Properties

Label: SNS

Data Time: 00:00:00

Data Interval: 00:06:00

Num Values: 1

Sequence: 1

Use calc time:

OK Cancel

(5)

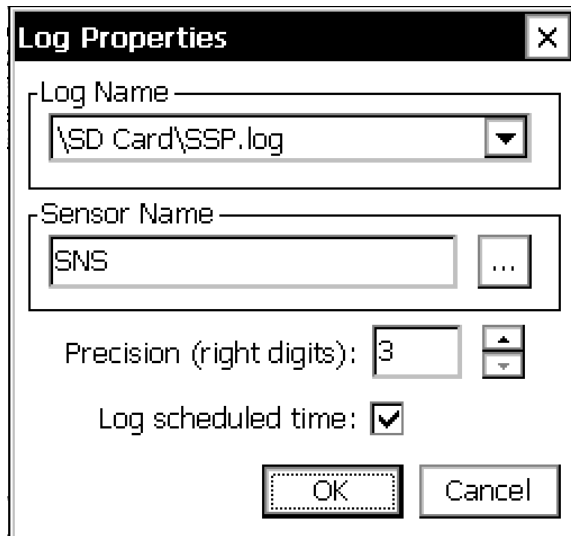

The "Log Properties" dialog box contains the following fields and controls:

- Log Name:** A text box containing "\SD Card\SSP.log" with a dropdown arrow on the right.
- Sensor Name:** A text box containing "SNS" and a button with three dots "..." on the right.
- Precision (right digits):** A numeric input field containing "3" and a vertical spinner control to its right.
- Log scheduled time:** A checked checkbox.
- Buttons:** "OK" and "Cancel" buttons at the bottom.

(6)

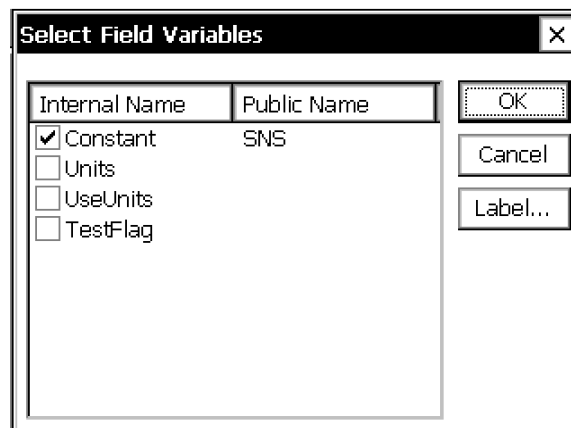

The "Select Field Variables" dialog box contains the following elements:

Internal Name	Public Name
<input checked="" type="checkbox"/> Constant	SNS
<input type="checkbox"/> Units	
<input type="checkbox"/> UseUnits	
<input type="checkbox"/> TestFlag	

Buttons: "OK", "Cancel", and "Label..." are located on the right side of the dialog.

Acronyms and Abbreviations

A	Ampere
CIL	Chesapeake Instrument Laboratory
cm	centimeter
CO-OPS	Center for Operational Oceanographic Products and Services
dB	decibel
DCP	data collection platform
ft	feet
GB	gigabyte
GPS	Global Positioning System
GOES	Geostationary Operational Environmental Satellite
GHz	gigahertz
I/O	input/output
IP	Internet protocol
LOS	line-of-sight
m	meter
mA	milliamp
MB	megabyte
mm	millimeters
mW	milliwatts
nJ	nanojoule
NOS	National Ocean Service
nm	nautical miles
NOAA	National Oceanic and Atmospheric Administration
OSTEP	Ocean Systems Test and Evaluation Program
POC	point of contact
PORTS [®]	Physical Oceanographic Real-time System
SIL	Seattle Instrument Laboratory
V	Volt
Vac	Volt alternating current
Vdc	Volt direct current